



M O T O R C O M P A N Y

Installation Manual

GA7200

AC Inverter

380 to 460V 1HP~450HP

200 to 230V 1HP~100HP

CAUTION AND WARNING:

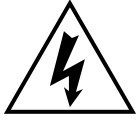

WARNING

- Do not change the wiring while power is applied to the circuit.
- After turning OFF the main circuit supply, do not touch circuit components until CHARGE LED is extinguished.
- Never connect power circuit output U (T1), V (T2), W (T3) to AC power supply.
- When the retry function (Cn-36) is selected, motor may restart suddenly after being stopped by momentary power loss.



CAUTION

- When mounting units in a separate enclosure, install a fan or other cooling device to keep the intake air temperature below 45°C.
- Do not perform a withstand voltage test to the inverter.
- All the constants of the inverter have been factory preset. Do not change the settings unnecessarily.

CONTENTS	Pages
1. GENERAL	4
1.1 SAFE OPERATION NOTES	4
1.2 PRODUCT NOTICES	4
1.3 GA7200 CONFIGURATION.....	5
2. RECEIVING	6
3. INSTALLATION	7
3.1 MOUNTING SPACE	7
3.2 LOCATION	8
4. WIRING	9
4.1 NOTES ON WIRING TO PERIPHERAL UNITS	9
4.2 CONNECTION DIAGRAM.....	10
4.3 TERMINAL FUNCTION	11
4.3.1 MAIN CIRCUIT TERMINALS	11
4.3.2 CONTROL CIRCUIT TERMINALS.....	11
4.3.3 MAIN CIRCUIT SCHEMATIC	12
4.4 WIRING PARTS.....	13
4.4.1 RECOMMENDED WIRING PARTS.....	13
4.4.2 CAUTIONS FOR WIRING	15
5. TEST OPERATION	17
5.1 CHECK BEFORE TEST OPERATION	17
5.2 SETTING THE LINE VOLTAGE SELECTING CONNECTOR	17
5.3 INPUT VOLTAGE SETTING	18
6. OPERATION	19
6.1 DIGITAL OPERATOR KEYPAD	19
6.2 DRIVE MODE AND PROGRAM (PRGM) MODE	20
6.3 BASIC CONSTANTS	23
6.4 DIGITAL OPERATOR PROGRAMMING	24
6.5 CONTROL TERMINAL SIGNAL OPERATION	26
7. MAINTENANCE	27
7.1 PERIODIC INSPECTION	27
7.2 SPARE PARTS	28
8. FAULT DISPLAY	32

	Pages
APPENDIX A. SPECIFICATION.....	34
APPENDIX B. DIMENSIONS	36
APPENDIX C. V/F PATTERN (Sn-02).....	37
APPENDIX D. TYPICAL CONNECTION DIAGRAM.....	38
APPENDIX E. OPTIONS	42
APPENDIX F. MOTOR APPLICATION NOTES	44
APPENDIX G. PERIPHERAL UNIT NOTES	45
APPENDIX H. CIRCUIT PROTECTION AND ENVIRONMENTAL RATINGS.....	46
APPENDIX I. DETAIL DIMENTIONS OF 250HP TO 450HP.....	49

1. GENERAL

1.1 SAFE OPERATION NOTES

Read this installation manual thoroughly before installation, operation, maintenance or inspection of the inverter. Only authorized personnel should be permitted to perform maintenance, inspections or parts replacement.

In this manual, notes for safe operation are classified as:

"WARNING" or "CAUTION".



: Indicates a potentially hazardous situation which, if not avoided, could result in death or serious injury to personnel.



: Indicates a potentially hazardous situation which, if not avoided, may result in minor or moderate injury to personnel and damage to equipment. It may also be used to alert against unsafe practices.

This inverter has been placed through demanding tests at the factory before shipment. After unpacking, check for the following:

1. Verify that part numbers on shipping carton and unit match the purchase order sheet and/or packing list.
2. Do not install or operate any inverter which is damaged or missing parts.
3. Do not install or operate any inverter which has no QC marking.

Contact your local distributor or TECO representative if any of the above have been found.

1.2 PRODUCT CHANGES

TECO reserves the right to discontinue or make modifications to the design of its products without prior notice, and holds no obligation to make modifications to products sold previously. TECO also holds no liability for losses of any kind which may result from this action.

1.3 GA7200 CONFIGURATION



2. RECEIVING



CAUTION

This GA7200 has been placed through demanding tests at the factory before shipment. After unpacking, check the following:

- Verify that part numbers on shipping carton and unit match the purchase order sheet (invoice) and/or packing list.
- Check to see if any shipping damage has occurred.
- If any part of GA7200 is damaged or lost, immediately notify the shipper.

3.2 LOCATION

Location of the equipment is important to achieve proper performance and normal operating life. The GA7200 should be installed in areas where the following conditions exist:

- Protected from rain or moisture.
- Protected from direct sunlight.
- Protected from corrosive gases or liquids.
- Free from airborne dust or metallic particles.
- Free from vibration.
- Free from magnetic noise (e.g. welding machines, power units)
- Ambient temperature:
 - +14 to 104°F, -10 to + 40°C (For enclosed type),
 - +14 to 113°F, -10 to + 45°C (For open chassis type)
- Free from combustible materials, gases, etc.



CAUTION

When mounting multiple units in a common enclosure, install a cooling fan or some other means to cool the air entering the inverter to at least 113 °F (45 °C) or below.

4. WIRING

4.1 NOTES ON WIRING TO PERIPHERAL UNITS

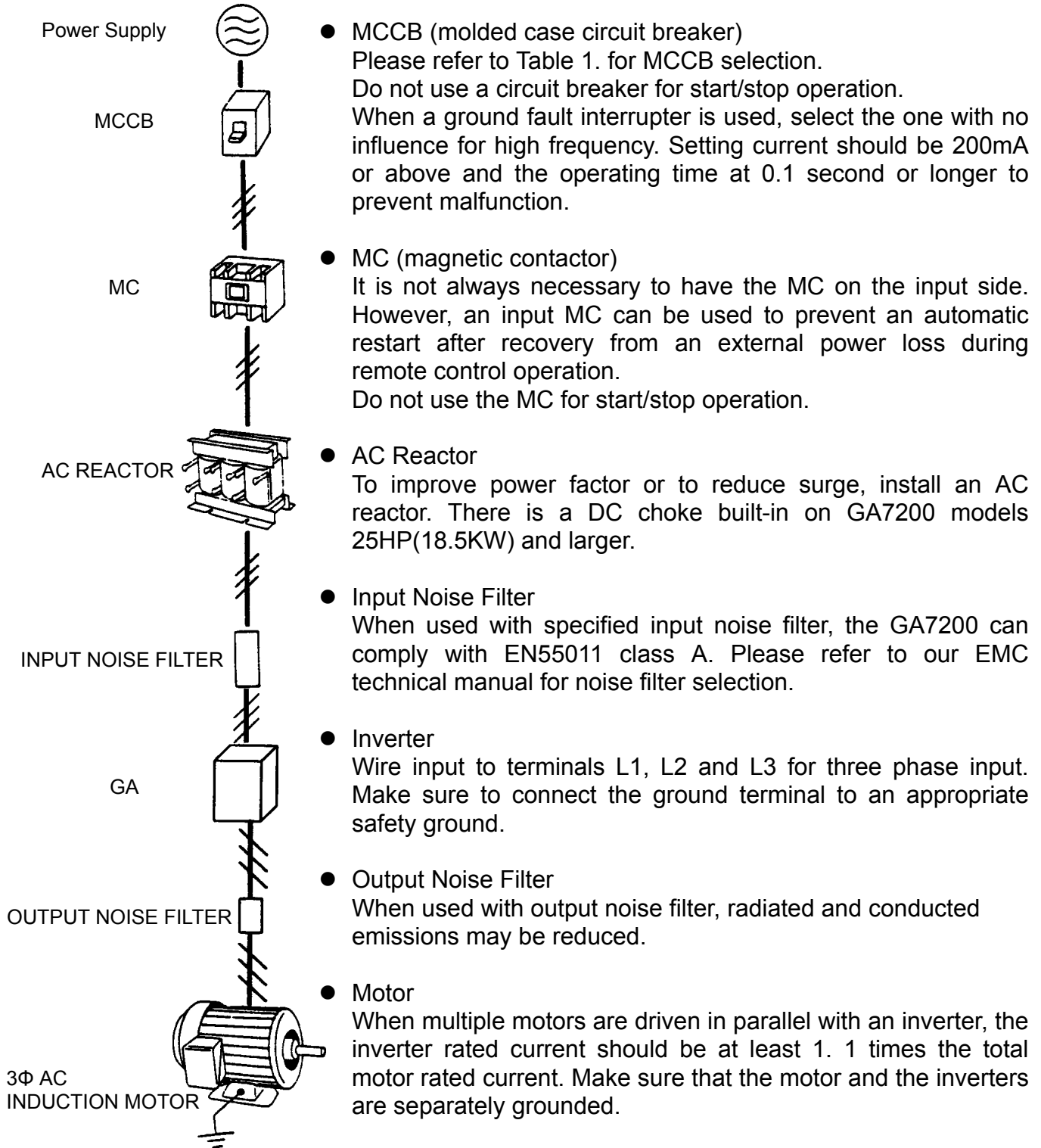

4.2 CONNECTION DIAGRAM

The following diagram shows interconnection of the main circuit and control circuit. With the digital operator, the motor can be operated by wiring the main circuit only. (Terminal Symbols: \odot indicates main circuit; \circ indicates control circuit).

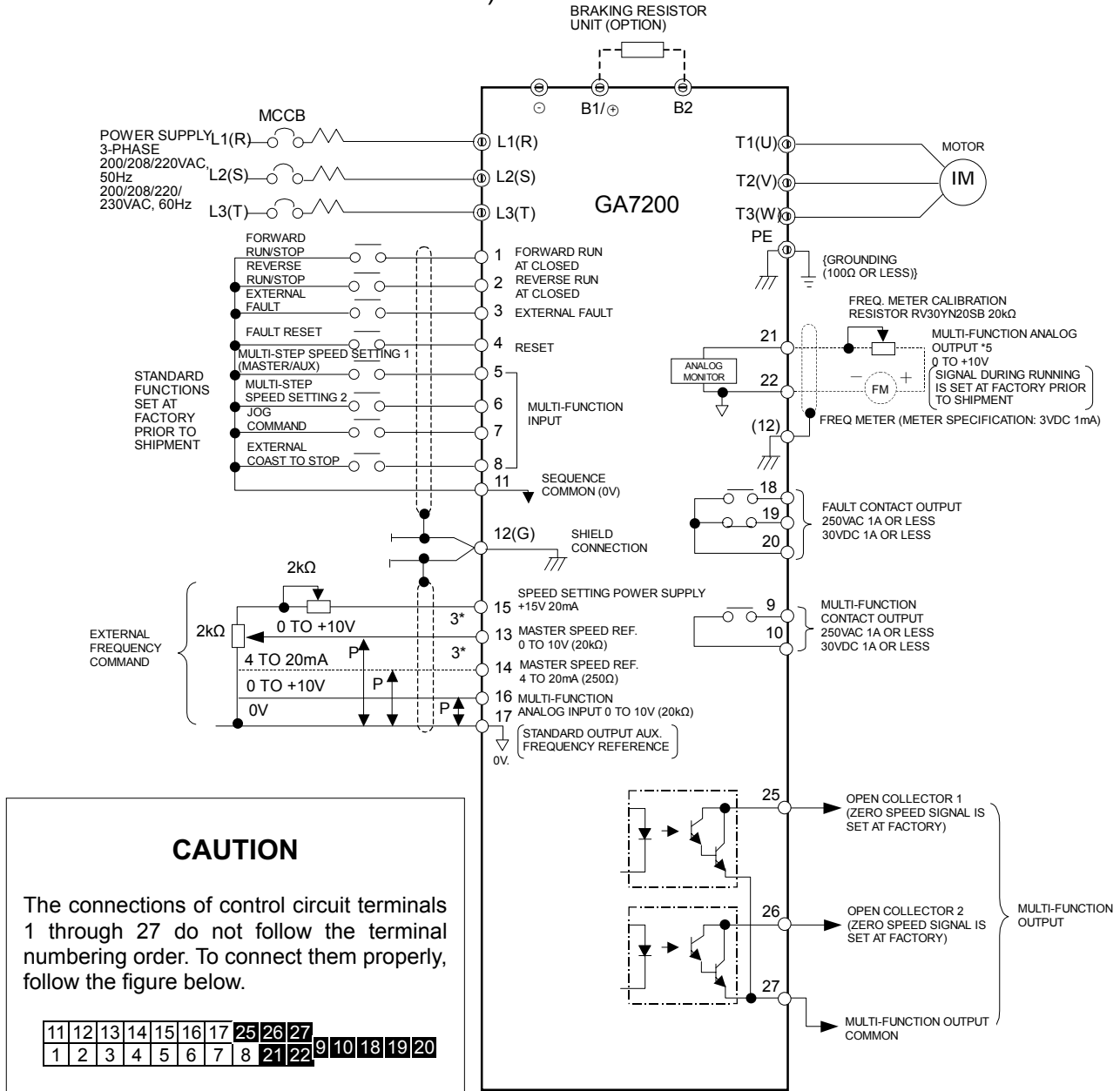

Notes:

- \odot indicates shielded wire and \circ indicates twisted pair shielded wire.
- Control circuit terminal 15 of +15V has maximum output current capacity of 20mA.
- Either external terminal 13 or 14 can be used.
(For simultaneous input, two signals are internally added in the unit).
- Multi-function analog output is an exclusive meter output such as frequency meter etc. and not available for the feedback control system.
- Control circuit terminal 12 is frame ground of the unit.

Fig. 2 Connection Diagram

4.3 TERMINAL FUNCTION

4.3.1 MAIN CIRCUIT TERMINALS

VOLTAGE	230V CLASS				460V CLASS			
Rating Terminal	1~10HP	15~20HP	25~30HP	40~100HP	1~10HP	15~20HP	25~60HP	75~450HP
R(L1)	Circuit input power supply							
S(L2)								
T(L3)								
U(T1)	Inverter output							
V(T2)								
W(T3)								
B1/⊕	● B1/⊕, B2: braking resistor	● B1/⊕, B2: braking resistor	-	-	● B1/⊕, B2: braking resistor	● B1/⊕, B2: braking resistor	-	-
B2								
⊖	● B1/⊕, ⊖: DC power supply	● B1/⊕, ⊕ 2: optional DCL	● ⊕1, ⊖: DC power supply or Braking Unit	⊕, ⊖: DC power supply or Braking Unit	● B1/⊕, ⊖: DC power supply	● B1/⊕, ⊕ 2: optional DCL	● ⊕1, ⊖: DC power supply or Braking Unit	● ⊕, ⊖: DC power supply or Braking Unit
⊕1, ⊕								
⊕2	-	● B1/⊕, ⊖: DC power supply	● ⊕2, ⊕3: DCL	-	-	● B1/⊕, ⊖: DC power supply	● ⊕2, ⊕3: DCL	-
⊕3	-	-	-	-	-	-	-	-
s	-		● r-s: cooling fan power supply	● r-s: cooling fan power supply	-		● r-s400: cooling fan power supply	● r-s: cooling fan power supply
r								
s400								
PE (⊖)	Grounding							

4.3.2 CONTROL CIRCUIT TERMINALS

Terminal	Functions	
1	Forward operation-stop signal	
2	Reverse operation-stop signal	
3	External fault input	
4	Fault reset	
5	Multi-function contact input: the following signals available to select. Forward/reverse select, run mode select, multi-speed select, jog frequency select, accel/decel time select, external fault, external coast to stop, hold command, inverter overheat prediction, DB command, aux. input effective, speed search, energy-saving operation.	
6		
7		
8		
9	Multi-function contact output: one of the following signals available to output. Output during running, zero speed, synchronized speed, arbitrary speed agreed, frequency detection, overtorque, undervoltage, run mode, coast to stop, braking resistor overheat, alarm, fault.	
10		
11	Sequence control input common terminal.	
12	Connection to shield sheath of signal lead.	
13	Master speed voltage reference (0 to 10V).	
14	Master speed current reference (4 to 20mA).	
15	+15V	
16	Aux. analog command: one of the following signals available to select. Frequency command, frequency gain, frequency bias, overtorque detection level, voltage bias, accel/decel rate, DB current.	
17	Common terminal for control circuit (0V).	
18	Fault contact output a (Closed at fault).	
19	Fault contact output b (Open at fault).	
20	Fault contact output common.	
21	Multi-function analog monitor (+).	Output current or output frequency is selectable.
22	Multi-function analog monitor (-).	
25	Multi-function PHC output 1.	The same as terminals 9 and 10
26	Multi-function PHC output 2.	
27	Multi-function PHC output common.	

4.3.3 MAIN CIRCUIT SCHEMATIC

- 230V: 1HP ~ 10HP
460V: 1HP ~ 10HP

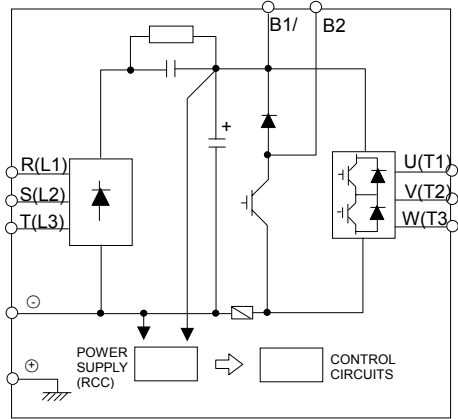

- 230V: 25HP ~ 30HP
460V: 25HP ~ 60HP

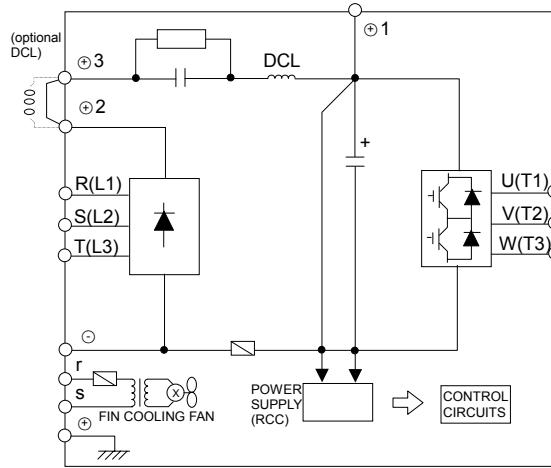

- 230V: 15HP ~ 20HP
460V: 15HP ~ 20HP

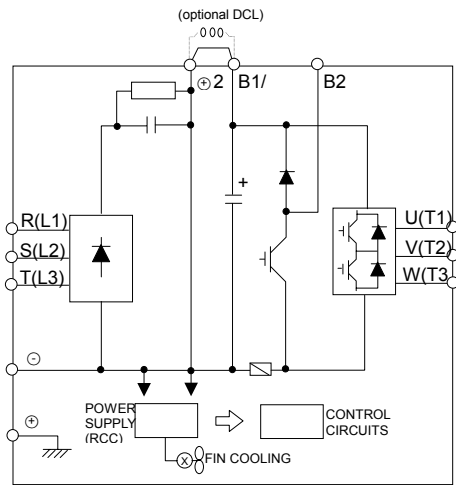

- 230V: 40HP ~ 100HP
460V: 75HP ~ 215HP

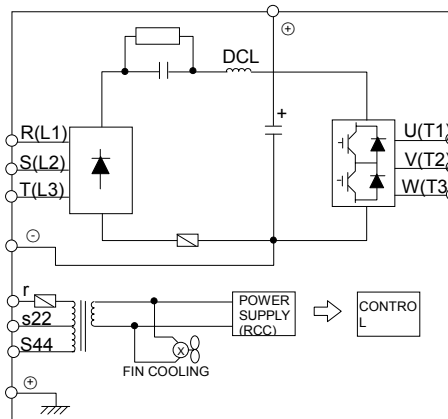

- 460V: 250HP ~ 450HP

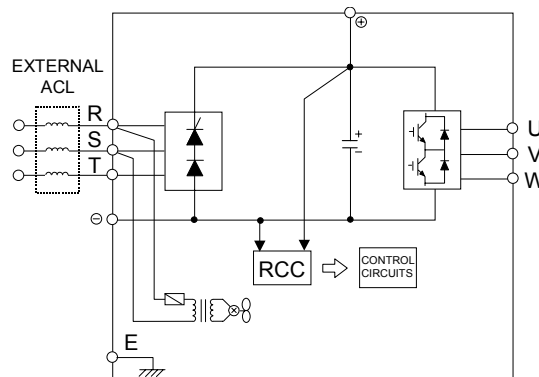

4.4 WIRING PARTS

4.4.1 RECOMMENDED WIRING PARTS

Be sure to connect MCCBs between power supply and GA7200 input terminals L1(R), L2(S), L3(T). Recommended MCCBs are listed in Table 1.

When a ground fault interrupter is used, select the one with no influence for high frequency. The current setting should be 200mA or over and operating time, 0.1 second or over to prevent malfunction.

(a) 230V SERIES

Max. Applicable Motor Output HP (KW) [Note 1]	Cable Size - mm ² (AWG)			Molded-Case Circuit Breaker [Note 4]	Magnetic Contactor [Note 4]
	Power Cable [Note 2]	Ground Cable [G]	Control Cable [Note 3]		
1 (0.75)	2 ~ 5.5 (14 - 10)	2 ~ 5.5 (14 - 10)	0.5 ~ 2 (20 - 14)	TO-50E (15A)	C-11L
2 (1.5)	2 ~ 5.5 (14 - 10)	3.5 ~ 5.5 (12 - 10)	0.5 ~ 2 (20 - 14)	TO-50E (20A)	C-11L
3 (2.2)	3.5 ~ 5.5 (12 - 10)	3.5 ~ 5.5 (12 - 10)	0.5 ~ 2 (20 - 14)	TO-50E (20A)	C-11L
5 (3.7)	5.5 (10)	5.5 (10)	0.5 ~ 2 (20 - 14)	TO-50E (30A)	C-16L
7.5 (5.5)	8 (8)	5.5 ~ 8 (10 - 9)	0.5 ~ 2 (20 - 14)	TO-100S (50A)	C-18L
10 (7.5)	8 (8)	5.5 ~ 8 (10 - 9)	0.5 ~ 2 (20 - 14)	TO-100S (60A)	C-25L
15 (11)	22 (4)	8 (8)	0.5 ~ 2 (20 - 14)	TO-100S (100A)	C-50L
20 (15)	30 (2)	8 (8)	0.5 ~ 2 (20 - 14)	TO-100S (100A)	C-65L
25 (18.5)	30 (2)	14 (6)	0.5 ~ 2 (20 - 14)	TO-225S (150A)	C-80G
30 (22)	38 (1)	14 (6)	0.5 ~ 2 (20 - 14)	TO-225S (175A)	C-100L
40 (30)	100 (4/0)	22 (4)	0.5 ~ 2 (20 - 14)	TO-225E (175A)	C-125G (170A)
50 (37)	60 x 2P (2/0 x 2P)	22 (4)	0.5 ~ 2 (20 - 14)	TO-225E (200A)	C-150G (200A)
60 (45)	60 x 2P (2/0 x 2P)	22 (4)	0.5 ~ 2 (20 - 14)	TO-225E (225A)	C-200 (235A)
75 (55)	60 x 2P (2/0 x 2P)	30 (2)	0.5 ~ 2 (20 - 14)	TO-400E (300A)	C-300L (400A)
100 (75)	100 x 2P (4/0 x 2P)	50 (1/0)	0.5 ~ 2 (20 - 14)	TO-400E (400A)	C-300L (400A)

(b) 460V SERIES

Max. Applicable Motor Output HP (KW) [Note 1]	Cable size (mm ²)			Molded-Case Circuit Breaker [Note 4]	Magnetic Contactor [Note 4]
	Power Cable [Note 2]	Ground Cable [G]	Control Cable [Note 3]		
1 (0.75)	2 ~ 5.5 (14 - 10)	2 ~ 5.5 (14 - 10)	0.5 ~ 2 (20 - 14)	TO-50E (15A)	C-11L
2 (1.5)	2 ~ 5.5 (14 - 10)	3.5 ~ 5.5 (12 - 10)	0.5 ~ 2 (20 - 14)	TO-50E (15A)	C-11L
3 (2.2)	2 ~ 5.5 (14 - 10)	3.5 ~ 5.5 (12 - 10)	0.5 ~ 2 (20 - 14)	TO-50E (15A)	C-11L
5 (3.7)	2 ~ 5.5 (14 - 10)	3.5 ~ 5.5 (12 - 10)	0.5 ~ 2 (20 - 14)	TO-50E (15A)	C-18L
7.5 (5.5)	3.5 ~ 5.5 (12 - 10)	3.5 ~ 5.5 (12 - 10)	0.5 ~ 2 (20 - 14)	TO-50E (20A)	C-18L
10 (7.5)	5.5 (10)	5.5 (10)	0.5 ~ 2 (20 - 14)	TO-50E (30A)	C-25L
15 (11)	8 ~ 14 (8 - 6)	8 (8)	0.5 ~ 2 (20 - 14)	TO-100S (50A)	C-25L
20 (15)	8 ~ 14 (8 - 6)	8 (8)	0.5 ~ 2 (20 - 14)	TO-100S (60A)	C-35L
25 (18.5)	14 (6)	8 (8)	0.5 ~ 2 (20 - 14)	TO-100S (75A)	C-50L
30 (22)	22 (4)	8 (8)	0.5 ~ 2 (20 - 14)	TO-100S (100A)	C-50L
40 (30)	22 (4)	8 (8)	0.5 ~ 2 (20 - 14)	TO-100S (100A)	C-65L
50 (37)	30 (2)	14 (6)	0.5 ~ 2 (20 - 14)	TO-100S (150A)	C-80L
60 (45)	50 (1/0)	14 (6)	0.5 ~ 2 (20 - 14)	TO-225E (175A)	C-100L (170A)
75 (55)	100 (4/0)	22 (4)	0.5 ~ 2 (20 - 14)	TO-225E (175A)	C-125G (170A)
100 (75)	60 x 2P (2/0 x 2P)	22 (4)	0.5 ~ 2 (20 - 14)	TO-225E (225A)	C-150G (200A)
125 (90)	60 x 2P (2/0 X 2P)	30 (2)	0.5 ~ 2 (20 - 14)	TO-400E (300A)	C-300L (400A)
150 (110)	60 x 2P (2/0 X 2P)	30 (2)	0.5 ~ 2 (20 - 14)	TO-400E (300A)	C-300L (400A)
175 (125)	100 x 2P (4/0 X 2P)	50 (1/0)	0.5 ~ 2 (20 - 14)	TO-400E (400A)	C-300L (400A)
215 (160)	100 x 2P (4/0 X 2P)	50 (1/0)	0.5 ~ 2 (20 - 14)	TO-400E (400A)	C-300L (400A)
250 (185)	325 x 2P (650 X 2P)	50 (1/0)	0.5 ~ 2 (20 - 14)	TO-400E (600A)	S-K400 (400A)
300 (220)	325 x 2P (650 X 2P)	60 (2/0)	0.5 ~ 2 (20 - 14)	TO-400E (800A)	S-K600 (630A)
350 (270)	325 x 2P (650 X 2P)	60 (2/0)	0.5 ~ 2 (20 - 14)	TO-400E (1000A)	S-K600 (630A)
450 (330)	325 x 2P (650 X 2P)	60 (2/0)	0.5 ~ 2 (20 - 14)	TO-400E (1000A)	S-K600 (630A)

[Note] 1. For Constant Torque Load.

2. Power Cable Include Cables to the Terminals R(L1), S(L2), T(L3), B1/⊕, B2, ⊖, ⊕1, ⊕2, ⊕3, U(T1), V(T2), W(T3).

3. Control Cable Include Cables to the Control Terminals ①~②, ③~④.

4. The Molded-Case Circuit Breaker and Magnetic Contactors Shown in Table 1 are Taian Products and are for reference only. Other manufactures' equivalent products may be selected.

5. The Magnetic contactors S-K400 and S-K600 are Mitsubishi Products and are for reference only. Other manufactures' equivalent products may be selected.

4.4.2 CAUTIONS FOR WIRING



CAUTION

The external interconnection wiring must be performed with the following procedures.

After completing GA7200 interconnections, be sure to check that connections are correct. Never use control circuit buzzer check.

(A) MAIN CIRCUIT INPUT/OUTPUT

- (1) Phase rotation of input terminals L1(R), L2(S), L3(T) is available in either direction. (Clockwise and counterclockwise).
- (2) When inverter output terminals T1(U), T2(V), and T3(W) are connected to motor terminals T1(U), T2(V), and T3(W), respectively, motor rotates counterclockwise. (Viewed from opposite side of drive end, upon forward operation command). To reverse the rotation interchange any two of the motor leads.
- (3) Never connect AC main circuit power supply to output terminals T1(U), T2(V), and T3(W). This may cause damage to the inverter.
- (4) Care should be taken to prevent contact of wiring leads with GA7200 cabinet. If this occurs, a short-circuit may result.
- (5) Never connect power factor correction capacitors or noise filters to GA7200 output.
- (6) Never open or close contactors in the output circuit unless inverter is properly sized.



CAUTION

- Lead size should be determined taking into account voltage drop of leads. Voltage drop can be obtained by the following equation: select such lead size that voltage drop will be within 2% of normal rated voltage.

phase-to-phase voltage drop (V)

$$= \sqrt{3} \times \text{lead resistance } (\Omega / \text{km}) \times \text{wiring distance(m)} \times \text{current(A)} \times 10^{-3} .$$

- Wiring length between inverter and motor.

If total wiring distance between inverter and motor is excessively long and inverter carrier frequency (main transistor switching frequency) is high, harmonic leakage current from the cable will increase to effect the inverter unit or peripheral devices. If the wiring distance between inverter and motor is long, reduce the inverter carrier frequency as shown below.

Wiring Distance between Inverter and Motor	Up to 100 ft.	Up to 165 ft.	Up to 328 ft.	328 ft. or more
Allowable Carrier Frequency	15kHz or less	10kHz or less	5kHz or less	2.5kHz or less

(B) GROUNDING (PE: Protective Earth)

Ground the GA7200 through ground terminal G (PE).

- (1) Ground resistance should be 100 ohms or less.
- (2) Never ground GA7200 in common with welding machines, motors, and other large-current electrical equipment, or ground pole. Run the ground lead in separate conduit from leads for large-current electrical equipment.
- (3) Use the ground leads which comply with AWG standards and make the sure the length is as short as possible.
- (4) Where several GA7200 units are used side by side, it is preferable to ground each unit separately to ground poles. However, connecting all the ground terminals of GA7200 in parallel while grounding only one of the GA7200's to the ground pole is also permissible (Fig. 3). Be sure not to form a loop with the ground leads.

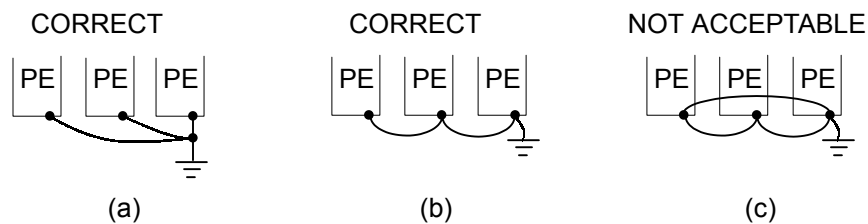

Fig. 3 Grounding of Three GA7200 Units

(C) CONTROL CIRCUIT

- (1) Separation of control circuit leads and main circuit leads: All signal leads must be separated from main circuit leads L1(R), L2(S), L3(T), B1/⊕, B2, ⊖, ⊕1, ⊕, ⊕2, ⊕3, T1(U), T2(V), T3(W) and other power cables to prevent erroneous operation caused by noise interference.
- (2) Control circuit leads 9, 10, 18, 19, 20 (contact output) must be separated from leads 1 to 8, 11 to 17, 21, 22 and 25 to 27.
- (3) Use twisted shielded or twisted pair shielded wire for the control circuit line and connect the shield sheath to the inverter terminal 12 to prevent malfunction caused by noise. See Fig.4. Wiring distance should be less than 164ft (50m).

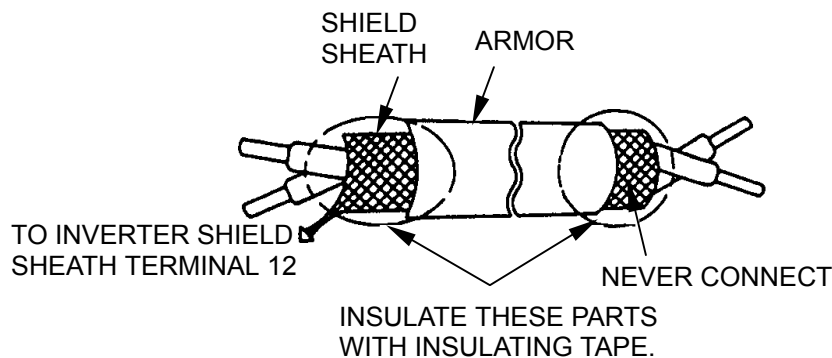

Fig. 4 Shielded Wire Termination

5. TEST OPERATION

To assure safety, prior to test operation, disconnect the coupling or belt which connects the motor with the machine so that motor operation is isolated. If an operation must be performed while the motor is directly connected to the machine, use great care to avoid any possible hazardous condition.

5.1 CHECK BEFORE TEST OPERATION

After completion of installation and wiring, check for

- (1) proper wiring
- (2) short-circuit due to wire clippings
- (3) loose screw-type terminals
- (4) proper load

5.2 SETTING THE LINE VOLTAGE SELECTING CONNECTOR FOR 460V CLASS 25HP (18.5kW) AND ABOVE

The cooling fan line voltage selecting connector shown in Fig. 5 must be set according to the type of main circuit power supply. Insert the connector at the position showing the appropriate line voltage.

The unit is preset at the factory to 440 line voltage.

- (a) 460V CLASS:
25HP ~ 60HP
250HP~450HP

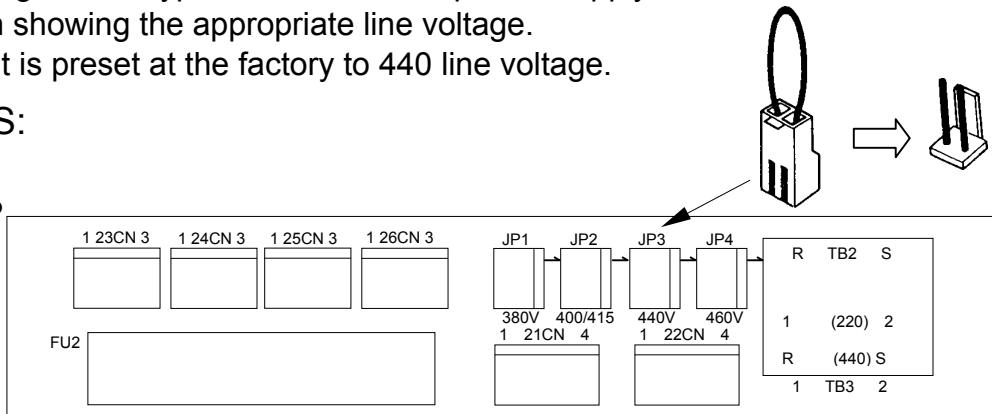

- (b) 460V CLASS:
75HP ~ 215HP

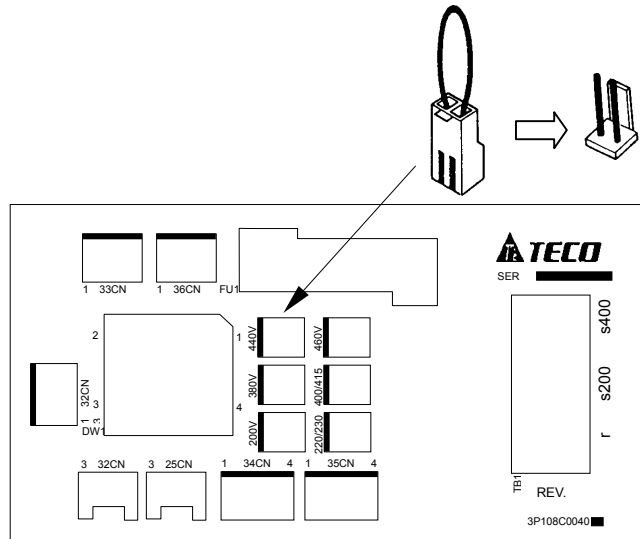

Fig. 5 Selection of Line Voltage

5.3 INPUT VOLTAGE SET

Set the power supply voltage to be used, by using the digital operator.
 The factory set for 220V class is 220V, and for the 440V class is 440V

Input Voltage Setting Method	Keypad Operation	Digital Operator Display	Remarks
POWER ON			
Frequency reference value display		F 0 0 . 0 0	
Change mode to PRGM	PRGM DRIVE	R n - 0 1	LED DRIVE OFF.
Select [n - 0 1]	DSPL	[n - 0 1]	
Data displayed	Depress three times.		
Set to 220V	DATA ENTER	2 0 0 . 0	
Change set value	RESET ^ v	2 2 0 . 0	
Write-in new set value	DATA ENTER	E n d	Displayed for 0.5 second.
Switch to DRIVE mode	PRGM DRIVE	F 0 0 . 0 0	LED DRIVE lights.

6. OPERATION

6.1 DIGITAL OPERATOR KEYPAD

Digital operator has DRIVE mode and PRGM mode. Selecting DRIVE mode enables the inverter to operate. PRGM mode enables the programs to be written-in. DRIVE and PRGM modes can be switched by  key only when stopped.

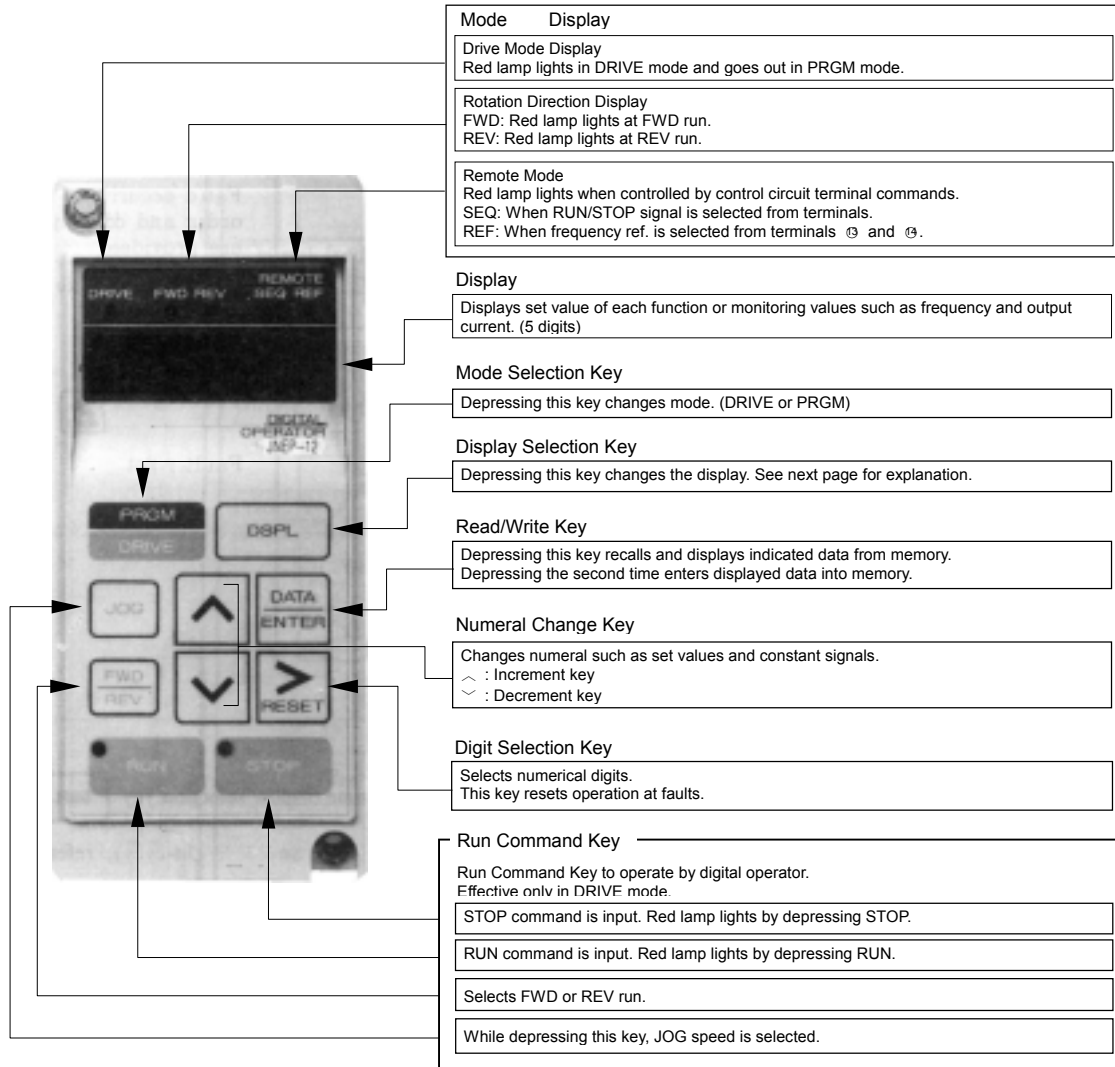

FREQUENCY SETTING

RUN Lamp	●	☀	☀	●
STOP Lamp	☀	●	☀	☀

☀ : LIT ☀ : BLINK ● : OFF

RUN or STOP lamp changes in accordance with the following operations.

6.2 DRIVE MODE AND PROGRAM (PRGM MODE)

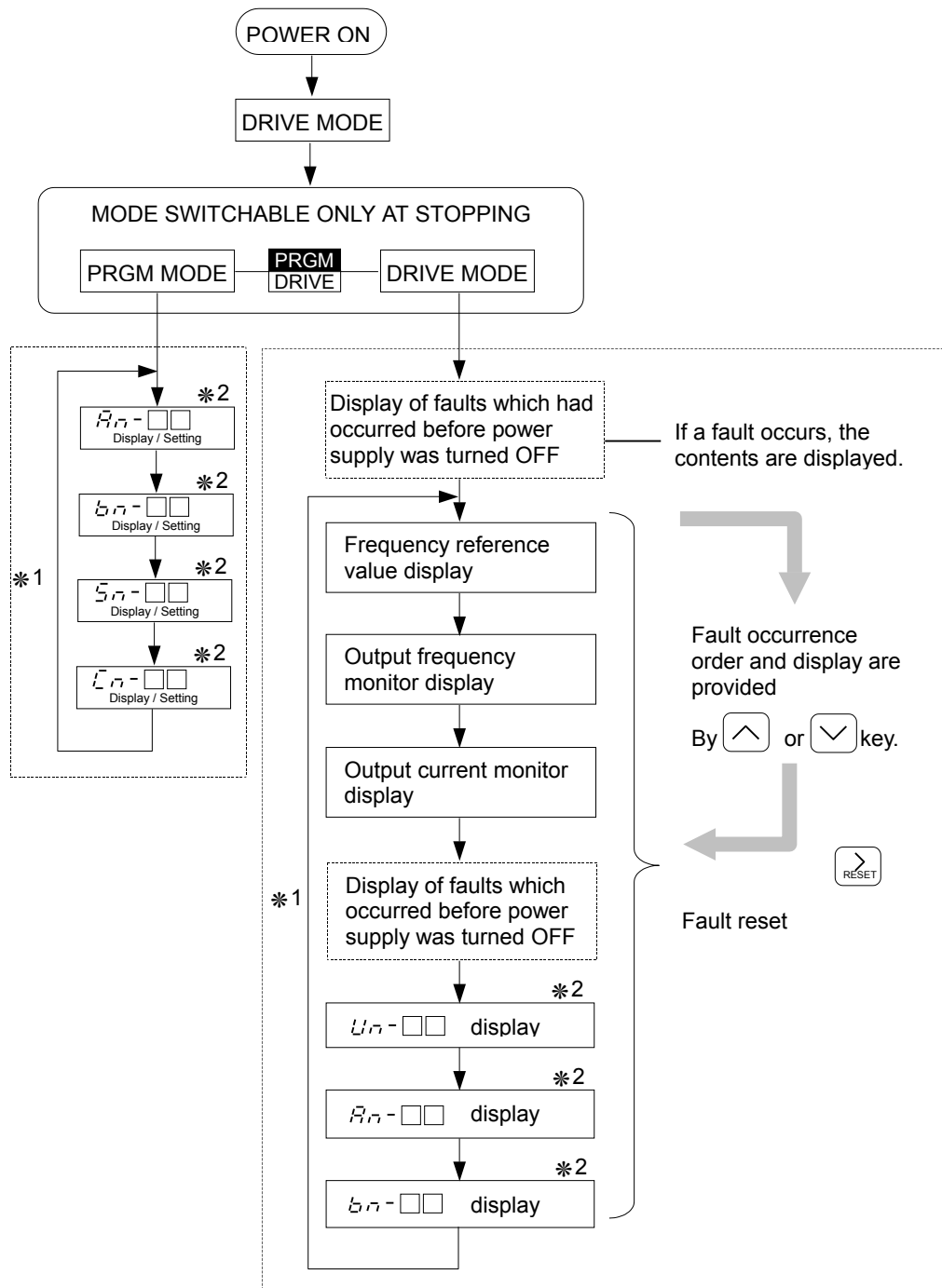



- *1: The constants group to be displayed is changed each time display selection key **[DSPL]** is depressed.
- *2: For details of constants (An-□□, bn-□□, Cn-□□, Sn-□□, Un-□□), refer to "BASIC CONSTANTS" on page 23.
- *3: Faults that occurred in the previous operation are displayed. Even if the power supply is turned OFF at fault occurrence, the constants are stored so that they are displayed after the power supply is turned ON again. (When no fault occurred, fault display of the previous operation is skipped).

■ DRIVE MODE

Monitor item is changed each time display selection key **DSPL** is depressed.

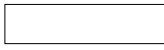
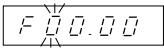
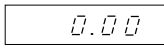
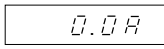
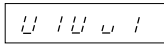
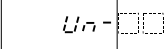
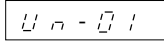
At fault occurrence, the digital operator displays the fault. Depressing  key changes to the previous display.

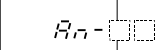
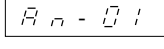
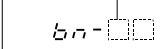
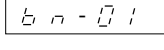
Description	Keypad Operation	Digital Operator Display	Remarks
Drive mode selected	PRGM DRIVE	LED DRIVE Lights.	
Display of faults which occurred before power supply was turned OFF			No display when no fault occurred before power supply was turned OFF.
Frequency reference value display/setting	DSPL		
Output frequency monitor display	DSPL		
Output current monitor display	DSPL		
Display of faults which occurred before power supply was turned OFF	DSPL		Example: Main circuit undervoltage trip.
 *	DSPL		Monitor value is displayed by  key.
 *	DSPL		
 *	DSPL		

*: Check the display data referring to "BASIC CONSTANTS" on page 23.

■ PRGM MODE

Monitor item is changed each time **DSPL** key is depressed.

Description	Keypad Operation	Digital Operator Display	Remarks
<pre> graph TD A[PRGM mode selected] --> B[An-00*] B --> C[bn-00*] C --> D[Sn-00*] D --> E[Cn-00*] E --> B </pre>	<p>PRGM DRIVE</p> <p>DSPL</p> <p>DSPL</p> <p>DSPL</p> <p>DSPL</p>	<p>An-01</p> <p>bn-01</p> <p>Sn-01</p> <p>Cn-01</p>	<p>LED DRIVE OFF.</p> <p>Data is displayed by DATA ENTER key.</p>

*: Check the display data referring to "BASIC CONSTANTS" on page 23.

[Typical Accel Time Setting]

Accel time can be set either in the DRIVE or PRGM mode.

Accel Time Setting	Keypad Operation	Digital Operator Display	Remarks
● Accel time constant selected.	DSPL	bn-01	
● Accel time data display.	DATA ENTER	10.0	10 seconds preset at factory.
● Set 12.5 seconds to accel time.		12.5	
● Write-in data.	DATA ENTER	End	Displayed for 0.5 second.

6.3 BASIC CONSTANTS

The constants described here are those required for basic operation.

■ U n - □□ (Monitor Type)

No.	Item	Display	Unit
U n - 01	Frequency reference	120.00	Hz
U n - 02	Output frequency	120.00	Hz
U n - 03	Output current	4.88	A
U n - 04	Voltage reference	2000	V
U n - 05	DC voltage (V.P-N)	Pn270	V
U n - 06	Output power/("-" displayed at regeneration)	0.75	kW

■ R n - □□ (Frequency Reference)

No.	Item	Display	Unit
R n - 01	Master frequency	120.00	Hz
R n - 09	Jog frequency	6.00	Hz

■ b n - □□ (Constant can be changed during operation)

No.	Item	Display	Unit
b n - 01	Acceleration time	10.0	sec
b n - 02	Deceleration time	10.0	sec
b n - 11	Frequency meter output gain	1.000	—

■ S n - □□ (System constants to be changed at stopping)

No.	Operation Conditions	Data (digits)				Factory Setting	
		1	2	3	4		
S n - 04	RUN MODE	Master frequency reference: Control terminal 13 or 14 input	—	—	—	0	0011
		Master frequency reference: Digital operator Rn-01	—	—	—	1	
		Operated by control terminal run command.	—	—	0	—	
		Operated by run command from the digital operator.	—	—	1	—	
	STOP MODE	Frequency deceleration to stop	0	0	—	—	
		Coast to stop	0	1	—	—	
		Full range DC injection braking to stop	1	0	—	—	
		Coast to stop (restart possible after the time set bn-02)	1	1	—	—	

■ C n - □□ (Control constants to be changed at stopping)

No.	Item	Display	Unit
C n - 09	Motor rated current (to agree with motor NP)	3.3	A
C n - 11	DC injection braking current	50	%
C n - 12	DC injection braking time at stop	0.5	sec
C n - 14	Frequency reference (upper limit)	100	%
C n - 15	Frequency reference (lower limit)	12	%
C n - 36	No. of retry operations at fault	5	times

6.4 DIGITAL OPERATOR PROGRAMMING

The following diagram describes typical digital operator programming in the pattern shown below.

■ OPERATION PATTERN

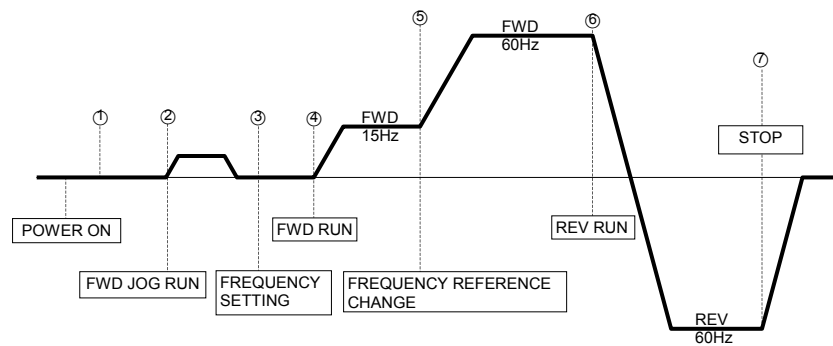

■ TYPICAL OPERATION

Description	Keypad Operation	Digital Operator Display	Remarks
<p>① POWER ON</p> <ul style="list-style-type: none"> ● Frequency reference value is displayed. ● Select output frequency monitor display. ● Check rotation direction (FWD at power ON). 			
<p>② FWD JOG RUN</p> <p>6Hz</p> <ul style="list-style-type: none"> ● Jog run operation. (Moving while key depressed.) <p>Cont'd</p>	<p>DSPL</p> <p>JOG</p>	 	<p>LED FWD lights.</p>

Description	Keypad Operation	Digital Operator Display	Remarks
<p>Cont'd</p> <p>③ Frequency setting</p> <ul style="list-style-type: none"> Select frequency reference value display. <p>15Hz</p> <ul style="list-style-type: none"> Change reference setting. Write-in set value. Stops blinking for 2 seconds. Select output frequency monitor display. 	<p>DSPL</p> <p>Depress three times</p> <p>RESET ^ v</p> <p>DATA ENTER</p> <p>DSPL</p>	<p>F 00.00</p> <p>F 15.00</p> <p>F 15.00</p> <p>0.00</p>	<p>Stops blinking for 2 seconds.</p>
<p>④ FWD run</p> <ul style="list-style-type: none"> FWD run operation <p>15Hz</p>	<p>RUN</p>	<p>15.00</p>	<p>LED <input checked="" type="checkbox"/> RUN lights.</p>
<p>⑤ Frequency set value change</p> <ul style="list-style-type: none"> Select frequency reference. <p>60Hz</p> <ul style="list-style-type: none"> Change set value. Write-in set value. Stops blinking for 2 seconds. Select output frequency monitor display. 	<p>DSPL</p> <p>Depress six times</p> <p>RESET ^ v</p> <p>DATA ENTER</p> <p>DSPL</p>	<p>F 15.00</p> <p>F 60.00</p> <p>F 60.00</p> <p>60.00</p>	<p>FWD run (60Hz).</p> <p>Stops blinking for 2 seconds.</p>
<p>⑥ REV run</p> <ul style="list-style-type: none"> Switch to REV run. <p>60Hz</p>	<p>FWD REN</p>	<p>-60.00</p>	<p>REV run (60Hz).</p> <p>LED <input checked="" type="checkbox"/> REV lights.</p>
<p>⑦ Stop</p> <ul style="list-style-type: none"> Deceleration to a stop. 	<p>STOP</p>	<p>0.00</p>	<p>LED <input checked="" type="checkbox"/> STOP lights.</p> <p>(LED <input checked="" type="checkbox"/> RUN blinks during deceleration.)</p>

6.5 CONTROL TERMINAL SIGNAL OPERATION

Description	Keypad Operation	Digital Operator Display	Remarks
<p>POWER ON</p> <ul style="list-style-type: none"> Frequency reference value displayed. Select PRGM mode. 	<p>PRGM DRIVE</p>	<p>F 00.00</p> <p>A n-0 1</p>	<p>LED DRIVE OFF</p>
<p>OPERATION CONDITIONS SET</p> <ul style="list-style-type: none"> S n-0 1 displayed. Set S n-0 4 Data displayed. Set data to 0000. 	<p>DSPL</p> <p>Depress twice.</p> <p>RESET ^ v</p> <p>DATA ENTER</p> <p>RESET ^ v</p>	<p>S n-0 1</p> <p>S n-0 4</p> <p>00 1 1</p> <p>00 00</p>	
<p>SET VALUE WRITE-IN</p> <ul style="list-style-type: none"> Check for "End" display. (Operation by control terminal signal enables). 	<p>DATA ENTER</p>	<p>E n d</p>	<p>Displayed for 0.5 second.</p>
<p>DRIVE MODE SELECTION</p> <ul style="list-style-type: none"> Change to DRIVE mode. 	<p>PRGM DRIVE</p>	<p>F 00.00</p>	<p>LED DRIVE ON.</p>
<p>FREQUENCY SETTING</p> <ul style="list-style-type: none"> Input and check for frequency value of control terminal 13 or 14. 		<p>F 60.00</p>	
<p>OUTPUT FREQUENCY DISPLAY</p> <ul style="list-style-type: none"> Change to output frequency display. 	<p>DSPL</p>	<p>0.00</p>	
<p>OPERATION CHECK</p> <ul style="list-style-type: none"> Closed/open among terminals 1 to 11 with terminals 7 to 11 closed to perform jog operation. 		<p>6.00</p>	<p>LED RUN lights.</p>
<p>RUN</p> <ul style="list-style-type: none"> After checking for normal operation, close among control terminals 1 and 11 to perform FWD run. 		<p>60.00</p>	<p>Increased to 60Hz. LED RUN lights.</p>
<p>STOP</p> <ul style="list-style-type: none"> Open among control terminals 1 to 11 to stop. 		<p>0.00</p>	<p>Decreased to 0 Hz. LED STOP lights.</p> <p>(LED RUN blinks during deceleration.)</p>

7. MAINTENANCE

7.1 PERIODIC INSPECTION

The GA7200 requires very few routine checks. It will function longer if it is kept clean, cool and dry. Observe precautions listed in "Location". Check for tightness of electrical connections, discoloration or other signs of overheating. Use Table 2 as your inspection guide. Before servicing, turn OFF AC main circuit power and be sure that CHARGE lamp is OFF.

Table 2 Periodic Inspection

Component	Check	Corrective Action
External terminals, unit mounting bolts, connectors, etc.	Loose screws	Tighten
	Loose connectors	Tighten
Cooling fins	Build-up of dust and dirt	Blow with dry compressed air of 39.2×10^4 to 58.8×10^4 Pa (57 to 85psi.) pressure.
Printed circuit board	Accumulation of conductive dust or oil	Blow with dry compressed air of 39.2×10^4 to 58.8×10^4 Pa (57 to 85psi.) pressure. If dust and oil cannot be removed, replace the board.
Cooling fan	Abnormal noise and vibration. Whether the cumulative operation time exceeds 20,000 hours or not.	Replace the cooling fan.
Power elements	Accumulation of dust and dirt	Blow with dry compressed air of 39.2×10^4 to 58.8×10^4 Pa (57 to 85psi) pressure.
Smoothing capacitor	Discoloration or odor	Replace the capacitor or inverter unit.

Note: Operating conditions as follows:

- Ambient temperature: Yearly average 30 °C, 86 °F
- Load factor: 80% or less
- Operating time: 12 hours or less per day

Standard Parts Replacement

Item Name	Replacement Cycle	Remarks
Cooling fan	2 or 3 years	Replace with a new product.
Smoothing capacitor	5 years	Replace with a new product. (Determine after examination).
Circuit Breakers and relays	—	Determine after examination.
Fuse	10 years	Replace with a new product.
Aluminum capacitor on PC board	5 years	Replace with a new product. (Determine after examination).

Note: Operating conditions as follows:

- Ambient temperature: Yearly average 30 °C, 86 °F
- Load factor: 80% or less
- Operating time: 20 hours or less per day

7.2 SPARE PARTS

As insurance against costly downtime, it is strongly recommended that renewal parts be kept on hand in accordance with the table below. When ordering renewal parts, please specify to your local distributor or TECO representative the following information: Part Name, Part Code No. and Quantity.

Table 3 Spare Parts for 230V Class

INVERTER & PART NAME		Control PC Board*	Power Board GA SERIES	Main Circuit Transistor	Main Circuit Diode	Fuse	Cooling Fan
HP	SPEC						
1	MODEL	-	-	6MBI15L-060	S20VT80	GSA-35	
	CODE	3H300D1490008	3P106C01900C1	227820021	277192012	279056019	
	Qty	1	1	1	1	1	
2	MODEL	-	-	6MBI20L-060	S20VT80	GSA-35	
	CODE	3H300D1490008	3P106C01900D9	277820030	277192012	279056019	
	Qty	1	1	1	1	1	
3	MODEL	-	-	6MBI30L-060	6RI30E-080	GSA-35	BP1202524H
	CODE	3H300D1490008	3P106C02000A0	277820048	277191016	279056019	3M903D1280005
	Qty	1	1	1	1	1	1
5	MODEL	-	-	6MBI50L-060	6RI30E-080	GSA-35	BP1202524H
	CODE	3H300D1490008	3P106C02100A5	277820056	277191016	279056019	3M903D1280005
	Qty	1	1	1	1	1	1
7.5	MODEL	-	-	MG75J2YS1	6RI50E-080M5	GSA-50	BP1202524H
	CODE	3H300D1490008	3P106C02200D2	277810018	277191041	279056027	3M903D1280005
	Qty	1	1	3	1	1	1
10	MODEL	-	-	MG100J2YS1	6RI75E-080	GSA-50	BP1202524H
	CODE	3H300D1490008	3P106C02200A1	277810034	277191032	279056027	3M903D1280005
	Qty	1	1	3	1	1	1
15	MODEL	-	-	7MBP100RA060	DF100BA80	80LET240V	AFB0824SH
	CODE	3H300D1490008	3P106C0650007	277831511	277192110	279053061	3H300D2370006
	Qty	1	1	1	1	1	2
20	MODEL	-	-	7MBP150RA060	DF150BA80	100LET240V	AFB0824SH
	CODE	3H300D1490008	3P106C06500A5	277831520	277192179	279053079	3H300D2370006
	Qty	1	1	1	1	1	2
25	MODEL	-	-	CM200DU-12H	DF200BA080	A30QS150-4L	4E-230B
	CODE	3H300D1490008	3P106C0670008	277810212	277192187	3M903D3960038	3M903D0450004
	Qty	1	1	3	1	1	2
30	MODEL	-	-	CM200DU-12H	DF200BA080	A30QS150-4L	4E-230B
	CODE	3H300D1490008	3P106C0670008	277810212	277192187	3M903D3960038	3M903D0450004
	Qty	1	1	3	1	1	2
40	MODEL	-	-	CM300HA-12H	2RI60E-080	A50QS250-4	4E-230B
	CODE	3H300D1490008	3P106C06400D4	3H324D0460000	277051532	3M903D3630011	3M903D0450004
	Qty	1	1	6	6	1	3

Table 3 Spare Parts for 230V Class (Cont'd)

INVERTER & PART NAME		Control PC Board*	Power Board GA SERIES	Main Circuit Transistor	Main Circuit Diode	Fuse	Cooling Fan
HP	SPEC						
50	MODEL	-	-	CM400HA-12H	2RI60E-080	A50QS300-4	4E-230B
	CODE	3H300D1490008	3P106C06400E2	277800179	277051532	3M903D3630020	3M903D0450004
	Qty	1	1	6	6	1	3
60	MODEL	-	-	1MBI600NP-060	2RI60E-080	A50QS350-4	4E-230B
	CODE	3H300D1490008	3P106C06400F1	277800195	277051532	3M903D3630038	3M903D0450004
	Qty	1	1	6	6	1	3
75	MODEL	-	-	1MBI600NP-060	2RI60E-080	A50QS450-4	4E-230B
	CODE	3H300D1490008	3P106C06400G9	277800195	277051532	3M903D3630046	3M903D0450004
	Qty	1	1	6	6	1	3
100	MODEL	-	-	CM300HA-12H	2RI100E-080	A50QS600-4	S175-2-HWB
	CODE	3H300D1490008	3P106C06400H7	3H324D0460000	277051516	3M903D3630054	279152115
	Qty	1	1	12	6	1	3

Table 4 Spare Parts for 460V Class

INVERTER & PART NAME		Control PC Board*	Power Board GA SERIES	Main Circuit Transistor	Main Circuit Diode	Fuse	Cooling Fan
HP	SPEC						
1	MODEL	-	-	6MBI8L-120	RM10TA-2H	80LF15	BP1202524H
	CODE	3H300D1490008	3P106C0430007	277820111	277190028	279053532	3M903D1280013
	Qty	1	1	1	1	1	1
2	MODEL	-	-	6MBI15L-120	RM10TA-2H	80LF15	BP1202524H
	CODE	3H300D1490008	3P106C0440002	277820129	277190028	279053532	3M903D1280013
	Qty	1	1	1	1	1	1
3	MODEL	-	-	6MBI15L-120	RM10TA-2H	80LF15	BP1202524H
	CODE	3H300D1490008	3P106C0440002	277820129	277190028	279053532	3M903D1280013
	Qty	1	1	1	1	1	1
5	MODEL	-	-	6MBI25L-120	6RI30G-160	80LF25	BP1202524H
	CODE	3H300D1490008	3P106C0450008	277810514	277191067	279053559	3M903D1280005
	Qty	1	1	1	1	1	1
7.5	MODEL	-	-	6MBI50L-120	6RI30G-160	80LF25	BP1202524H
	CODE	3H300D1490008	3P106C04500A6	277810522	277191067	279053559	3M903D1280005
	Qty	1	1	3	1	1	1
10	MODEL	-	-	6MBI50L-120	6RI30G-160	80LF25	BP1202524H
	CODE	3H300D1490008	3P106C04500A6	277810522	277191067	279053559	3M903D1280005
	Qty	1	1	3	1	1	1
15	MODEL	-	-	7MBP75RA120	DF75AA160	FWH-80A	AFB0824SH
	CODE	3H300D1490008	3P106C06500B3	277831538	277192128	279055519	3H300D2370006
	Qty	1	1	1	1	1	2
20	MODEL	-	-	7MBP75RA120	DF75AA160	FWH-80A	AFB0824SH
	CODE	3H300D1490008	3P106C06500C1	277831538	277192128	279055519	3H300D2370006
	Qty	1	1	1	1	1	2
25	MODEL	-	-	CM100DU-24H	DF75AA160	A50QS80-4	4E-230B
	CODE	3H300D1490008	3P106C06700A6	277810221	277192128	3M903D3630101	3M903D0450004
	Qty	1	1	3	1	1	2
30	MODEL	-	-	CM100DU-24H	DF100AA160	A50QS100-4	4E-230B
	CODE	3H300D1490008	3P106C06700A6	277810221	277192144	3M903D3630071	3M903D0450004
	Qty	1	1	3	1	1	2
40	MODEL	-	-	CM150DU-24H	DF150AA160	A50QS150-4	4E-230B
	CODE	3H300D1490008	3P106C06700A6	277810239	277192152	3M903D3630089	3M903D0450004
	Qty	1	1	3	1	1	2
50	MODEL	-	-	CM200DU-24H	DF200AA160	A50QS150-4	4E-230B
	CODE	3H300D1490008	3P106C06700B4	277810247	277192161	3M903D3630089	3M903D0450004
	Qty	1	1	3	1	1	2
60	MODEL	-	-	CM200DU-24H	DF200AA160	A50QS150-4	4E-230B
	CODE	3H300D1490008	3P106C06700B4	277810247	277192161	3M903D3630089	3M903D0450004
	Qty	1	1	3	1	1	2
75	MODEL	-	-	CM300HA-24H	2RI60G-160	A50QS250-4	4E-230B
	CODE	3H300D1490008	3P106C0640001	277800144	277051541	3M903D3630011	3M903D0450004
	Qty	1	1	6	6	1	2
100	MODEL	-	-	CM400HA-24H	2RI60G-160	A50QS300-4	4E-230B
	CODE	3H300D1490008	3P106C06400A0	277800187	277051541	3M903D3630020	3M903D0450004
	Qty	1	1	6	6	1	2
125	MODEL	-	-	CM600HA-24H	2RI100G-160	A50QS350-4	4E-230B
	CODE	3H300D1490008	3P106C0640001	277800209	277051524	3M903D3630038	3M903D0450004
	Qty	1	1	6	6	1	2

Table 4 Spare Parts for 460V Class (Cont'd)

INVERTER & PART NAME		Control PC Board*	Power Board GA SERIES	Main Circuit Transistor	Main Circuit Diode	Fuse	Cooling Fan
HP	SPEC						
150	MODEL	-	-	CM600HA-24H	2R1100G-160	A50QS450-4	S175-2-HWB
	CODE	3H300D1490008	3P106C06400B8	277800209	277051524	3M903D3630046	279152115
	Qty	1	1	6	6	1	3
175	MODEL	-	-	CM600HA-24H	2R1100G-160	A50QS450-4	S175-2-HWB
	CODE	3H300D1490008	3P106C0640001	277800209	277051524	3M903D3630046	279152115
	Qty	1	1	6	6	1	3
215	MODEL	-	-	CM400HA-24H	2R1100G-160	A50QS600-4	S175-2-HWB
	CODE	3H300D1490008	3P106C06400C6	277800187	277051524	3M903D3630054	279152115
	Qty	1	1	12	6	1	3
250	MODEL	-	-	Skiip1013GB122-2DL	SKKH330/16E		2RRE45250x56R
	CODE	4H300D3940004	4P106C0060009	4M903D2020001	4M903D1990006		4M903D1940009
	Qty	1	1	3	3		1
350	MODEL	-	-	Skiip1203GB122-2DL	SKKH500/16E		2RRE45250x56R
	CODE	4H300D3940004	4P106C0060009	4M903D2030006	4M903D2000000		4M903D1940009
	Qty	1	1	3	3		2
450	MODEL	-	-	Skiip1513GB122-3DL	SKKH500/16E		2RRE45250x56R
	CODE	4H300D3940004	4P106C0060009	4M903D2040001	4M903D2000000		4M903D1940009
	Qty	1	1	3	3		2

*1. Control Board GA7200: 3H300D1490008 × 1PCS

2. Digital Operator GA7200: 3H300C0100003 × 1PCS

8. FAULT DISPLAY

As Table 5 shows, the faults that the GA7200 detects are classified into faults and alarms. If a problem occurs, the fault contact is output and the motor coasts to a stop. When an alarm is issued, the digital operator indicates the alarm for warning.

Table 5 Fault Display and Details

Indication	Fault Display	Description	Corrective Action
$Uu1$	Undervoltage (PUV)	Two seconds are counted after detection of low voltage.	<ul style="list-style-type: none"> ● Check wiring of line units. (power supply side) ● Correct power supply voltage.
$Uu2$	Undervoltage (CUV)	Control circuit becomes low voltage during operation.	
$Uu3$	Undervoltage (MC-ANS fault)	Main circuit magnetic contactor does not operate correctly.	
GF	Grounding	Grounding current > approx. 50% of inverter rated current	<ul style="list-style-type: none"> ● Check that motor insulation not deteriorated. ● Check that there is no damage to wiring at load side.
oC	Overcurrent	Inv. output current >200% of Inv. rated current	<ul style="list-style-type: none"> ● Check the motor winding resistance and ground. ● Increase accel time.
ou	Overvoltage	Detection level: Approx. 400V for 230V class Approx. 800V for 460V class [(Cn-01) ≥ 400V] Approx. 700V for 460V class [(Cn-01) < 400V]	Increase decel time and/or add braking resistor.
FU	Fuse blown	—	Check short-circuit at load, ground fault, etc.
oH	Radiation fin overheated	Fin temperature 90℃ (194℉)	Check fan or ambient temperature (less than 45℃, 113℉).
$oL1$	Overload	Protect the motor.	Measure motor temperature-rise and reduce load, then reset V/f.
$oL2$	Overload	Protect the inverter.	Reduce load, and increase accel time, then reset V/f.
$oL3$	Overtorque	When selecting inv. output OFF at "inv. output current > overtorque detection level" and overtorque detection.	—
rr	Regenerative transistor fault	—	Replace transistor.
rH	Braking resistor overheated	Protect braking resistor incorporated in inverter unit.	Reduce regenerative load, or use other resistor unit installed separately.
$EF3$	Control circuit terminal ⊕ fault	Stop mode selection possible	Check state of input terminal with data Un-07. (Replace inverter if "!" is indicated as the state of open terminal.)
$EF5$	Control circuit terminal ⊕ fault		
$EF6$	Control circuit terminal ⊕ fault		
$EF7$	Control circuit terminal ⊖ fault		
$EF8$	Control circuit terminal ⊕ fault		

Table 5 Fault Display and Details (Cont'd)

Indication	Fault Display	Description	Corrective Action
<i>b u s</i>	Communication inverter card SC-C (option) communication error	Stop mode selection possible	Check communication cable between communication interface card (SC-C) and master controller.
<i>[PF00]</i>	Operator communication error	Communication between inverter and operator is not established 5 seconds after the power supply is turned ON.	<ul style="list-style-type: none"> ● Insert operator connector again. ● Replace control board.
<i>[PF01]</i>	Operator communication error	Communication error occurs 2 seconds after communication between inverter and operator is established after the power supply is turned ON.	<ul style="list-style-type: none"> ● Insert operator connector again. ● Replace control board.
<i>[PF02]</i>	Control circuit fault	Inverter fault	<ul style="list-style-type: none"> ● Replace control PC board.
<i>[PF03]</i>	NV-PAM (S-RAM) fault		
<i>[PF04]</i>	NV-RAM (BCC, Access Code) fault		
<i>[PF05]</i>	A/D converter fault in CPU		
<i>[PF06]</i>	Optional connection fault		



CAUTION

Do not replace the DC bus fuse without first checking the output transistors.

APPENDIX A

SPECIFICATIONS (GA7200 SERIES)

230V CLASS BASIC SPECIFICATIONS

INVERTER (HP)		1	2	3	5	7.5	10	15	20	25	30	40	50	60	75	100
MAX. APPLICABLE MOTOR OUTPUT HP (KW)*1		1 (0.75)	2 (1.5)	3 (2.2)	5 (3.7)	7.5 (5.5)	10 (7.5)	15 (11)	20 (15)	25 (18.5)	30 (22)	40 (30)	50 (37)	60 (45)	75 (55)	100 (75)
Output Characteristics	Inverter Capacity (KVA)	2.1	2.7	4.1	6.9	10.3	13.7	20.6	27.4	34	41	54	68	78	96	128
	Rated Output Current (A)	4.8	6.4	9.6	16	24	32	48	64	80	96	130	160	183	224	300
	Max. Output Frequency	3-Phase, 200/208/220/230V (Proportional to input voltage)														
	Rated Output Frequency	Up to 400Hz available														
Power Supply	Rated Input Voltage And Frequency	3-Phase 200/208/220V, 50Hz 200/208/220/230V, 60Hz														
	Allowable Voltage Fluctuation	+10% ~ -15%														
	Allowable Frequency Fluctuation	±5%														

460V CLASS

INVERTER (HP)		1	2	3	5	7.5	10	15	20	25	30	40	50	60	75	100	125	150	175	215	250	350	450
MAX. APPLICABLE MOTOR OUTPUT HP (KW)*1		1 (0.75)	2 (1.5)	3 (2.2)	5 (3.7)	7.5 (5.5)	10 (7.5)	15 (11)	20 (15)	25 (18.5)	30 (22)	40 (30)	50 (37)	60 (45)	75 (55)	100 (75)	125 (90)	150 (110)	175 (132)	215 (160)	250 (185)	350 (264)	450 (330)
Output Characteristics	Inverter Capacity (KVA)	2.2	3.4	4.1	6.9	10.3	13.7	20.6	27.4	34	41	54	68	82	110	138	180	195	230	260	290	385	514
	Rated Output Current (A)	2.6	4.0	4.8	8	12	16	24	32	40	48	64	80	96	128	165	192	224	270	300	340	450	600
	Max. Output Frequency	3 Phase, 380/400/415/440/460V (Proportional to input voltage)																					
	Rated Output Frequency	Up to 400Hz available																					
Power Supply	Rate Input Voltage And Frequency	3 Phase, 380/400/415/440/460V 50/60Hz																					
	Allowable Voltage Fluctuation	+10% ~ -15%																					
	Allowable Frequency Fluctuation	±5%																					

● based on 4 pole motor/460V

APPENDIX B

DIMENSIONS (inches)

■ Open Chassis type (IP00)

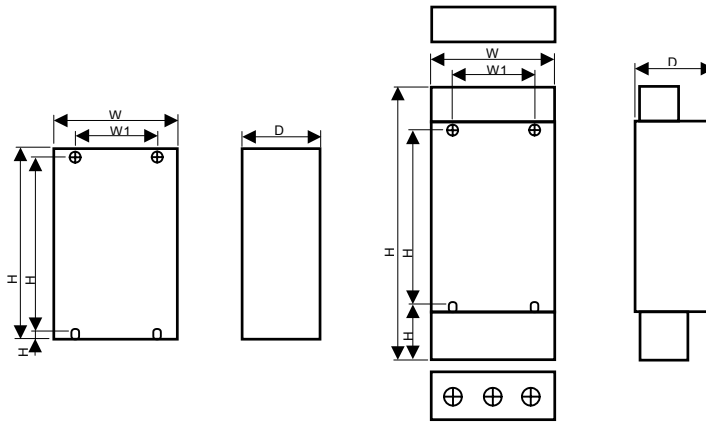

VOLT-AGE	INVERTER HP	APPROXIMATE DIMENSIONS (in.)														DCL	
		OPEN CHASSIS TYPE (IP00)							Weight (lbs.)	ENCLOSED TYPE (NEMA1)(IP20)							Weight (lbs.)
		W	H	D	W1	H1	d	W		H	D	W1	H1	d			
230V	1	8.05	11.97	5.12	7.09	11.22	M6	9	8.07	12.00	5.12	7.09	11.22	M6	9	ACL-OPTION	
	2																
	3	8.05	11.97	6.50	7.09	11.22	M6	15	8.07	12.00	6.50	7.09	11.22	M6	16		
	5																
	7.5	8.05	11.97	7.87	7.09	13.19	M6	22	8.07	13.98	7.87	7.09	13.19	M6	22		
	10																
	15	10.43	14.17	9.65	9.65	13.39	M6	26	10.43	14.17	9.65	9.65	13.39	M6	27		OPTION
	20																
	25	11.16	20.67	12.09	8.66	19.88	M8	71	11.48	29.33	12.09	8.66	19.88	M8	77		BUILT-IN
	30																
40	18.07	31.10	12.78	12.60	29.92	M10	165	18.19	43.50	12.78	12.60	29.92	M10	179			
50							168							181			
60							174							188			
75							174							194			
100	23.58	39.37	15.02	18.11	37.80	M12	265	23.70	51.38	15.02	18.11	37.80	M12	287			
460V	1	8.05	3.94	6.50	7.09	13.19	M6	15	8.07	13.98	6.50	7.09	13.19	M6	16	ACL-OPTION	
	2																
	3	8.05	13.94	7.87	7.09	13.19	M6	22	8.07	13.98	7.87	7.09	13.19	M6	22		
	5																
	7.5	8.05	13.94	7.87	7.09	13.19	M6	22	8.07	13.98	7.87	7.09	13.19	M6	22		
	10																
	15	10.43	14.17	9.65	9.65	13.39	M6	26	10.43	14.17	9.65	9.65	13.39	M6	27	OPTION	
	20																
	25	11.16	20.67	12.09	8.66	19.88	M8	71	11.48	29.33	12.09	8.66	19.88	M8	77	BUILT-IN	
	30																
	40	13.54	24.80	12.78	9.84	24.02	M8	102	13.86	37.20	12.78	9.84	24.02	M8	110		
	50																
	60																
	75																
	100	18.07	31.10	12.78	12.60	29.92	M10	176	18.19	43.50	12.80	12.60	29.92	M10	190		
	125							179							192		
	150	23.58	39.37	15.02	18.11	37.80	M12	265	23.70	51.38	15.02	18.11	37.80	M12	287		
	175							265							287		
215	287							309									
250*1	356							369									
350*1	28.74	48.43	15.04	27.17	36.61	M12	378	28.74	53.36	15.04	27.17	36.61	M12	388	ACL-option		
450*1							423							432			

*1. Please refer to Appendix I for detail dimensions.

APPENDIX C

V/f PATTERN (Sn-02)

The following V/f patterns can be selected by Sn-02. Set inverter input voltage to Cn-01 before selecting V/f pattern.

- Sn-02 data ① to ⑤ : Factory preset data
- Sn-02 data ⑥ : Possible to set freely (The following shows the data after initialization).

■ 230V CLASS V/F PATTERN SELECTION*

Application	Specifications	Sn-02	V/f Pattern	Application	Specifications	Sn-02	V/f Pattern
General-purpose	50Hz	①		High Starting Torque	50Hz Low Starting torque	⑧	
	60Hz	60Hz Saturation	① ⑥		High Starting Torque	High Starting torque	⑨
		50Hz Saturation	②	60Hz Low Starting torque		⑩	
	72Hz	③		Constant HP Operation (Machine Tools)	90Hz	⑪	
Variable Torque Operation (Fans and Pumps)	50Hz	Variable torque 1	④		Constant HP Operation (Machine Tools)	120Hz	⑫
		Variable torque 2	⑤	180Hz			
	60Hz	Variable torque 3	⑥			180Hz	⑭
		Variable torque 4	⑦				

* Voltage values are doubled for 460V class.

Notes: 1. Consider the following points as V/f pattern selecting conditions.

- (1) Select a pattern in accordance with the motor voltage-frequency characteristics.
- (2) Select a pattern in accordance with the motor maximum r/min.
2. High starting torque must be selected only in the following cases.
 - (1) Wiring distance is long (approx. 492ft. (150m) or more).
 - (2) Voltage drop at starting is large.
 - (3) AC reactor is inserted in inverter input or output.
 - (4) A motor smaller than the maximum applicable inverter is used.

APPENDIX D

TYPICAL CONNECTION DIAGRAM

(1) Braking Unit

For models 230V/460V 20HP(15KW) or smaller
(Braking transistor built-in as standard)

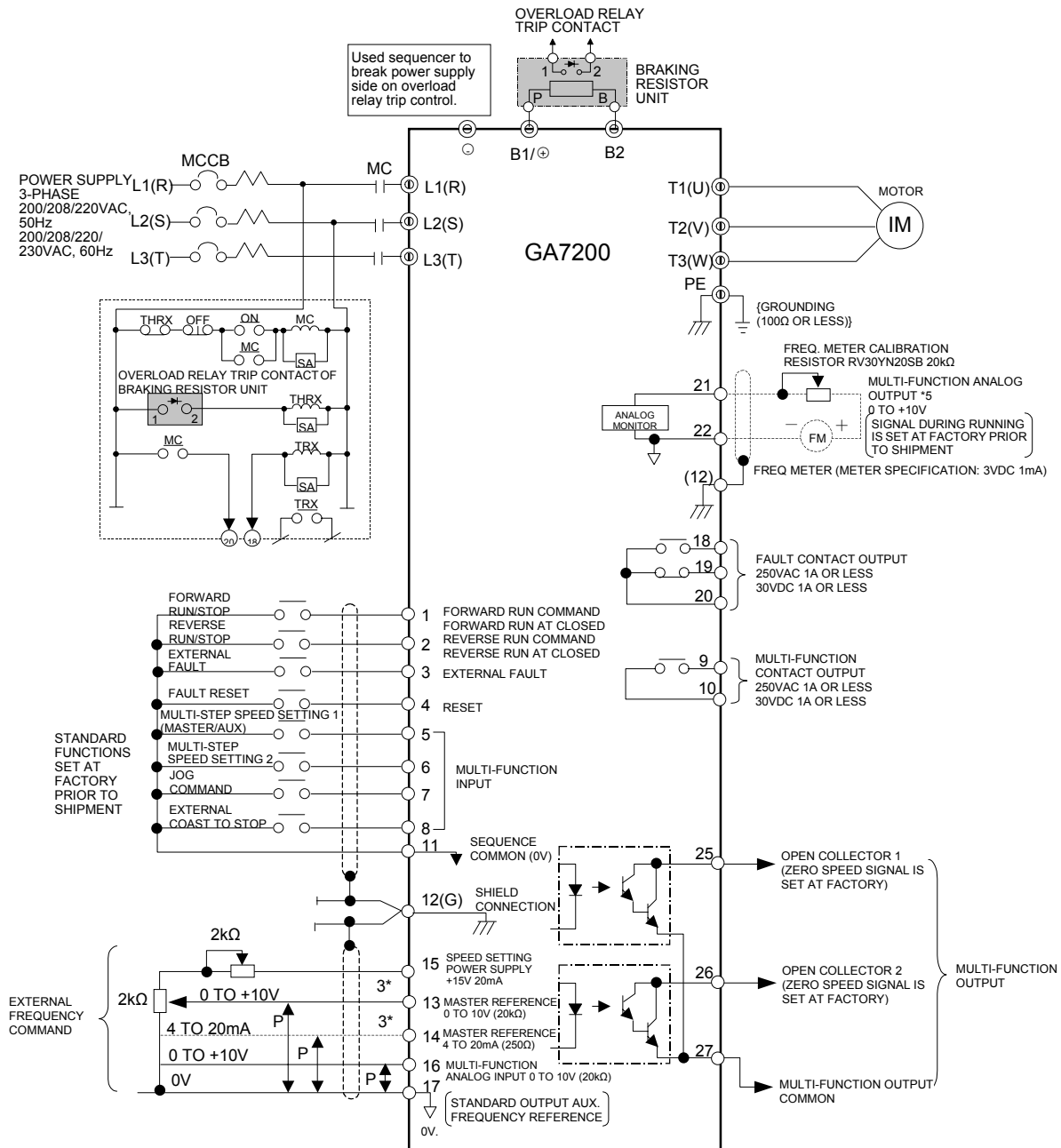

For models 230V/460V 25HP (18.5KW) or larger.

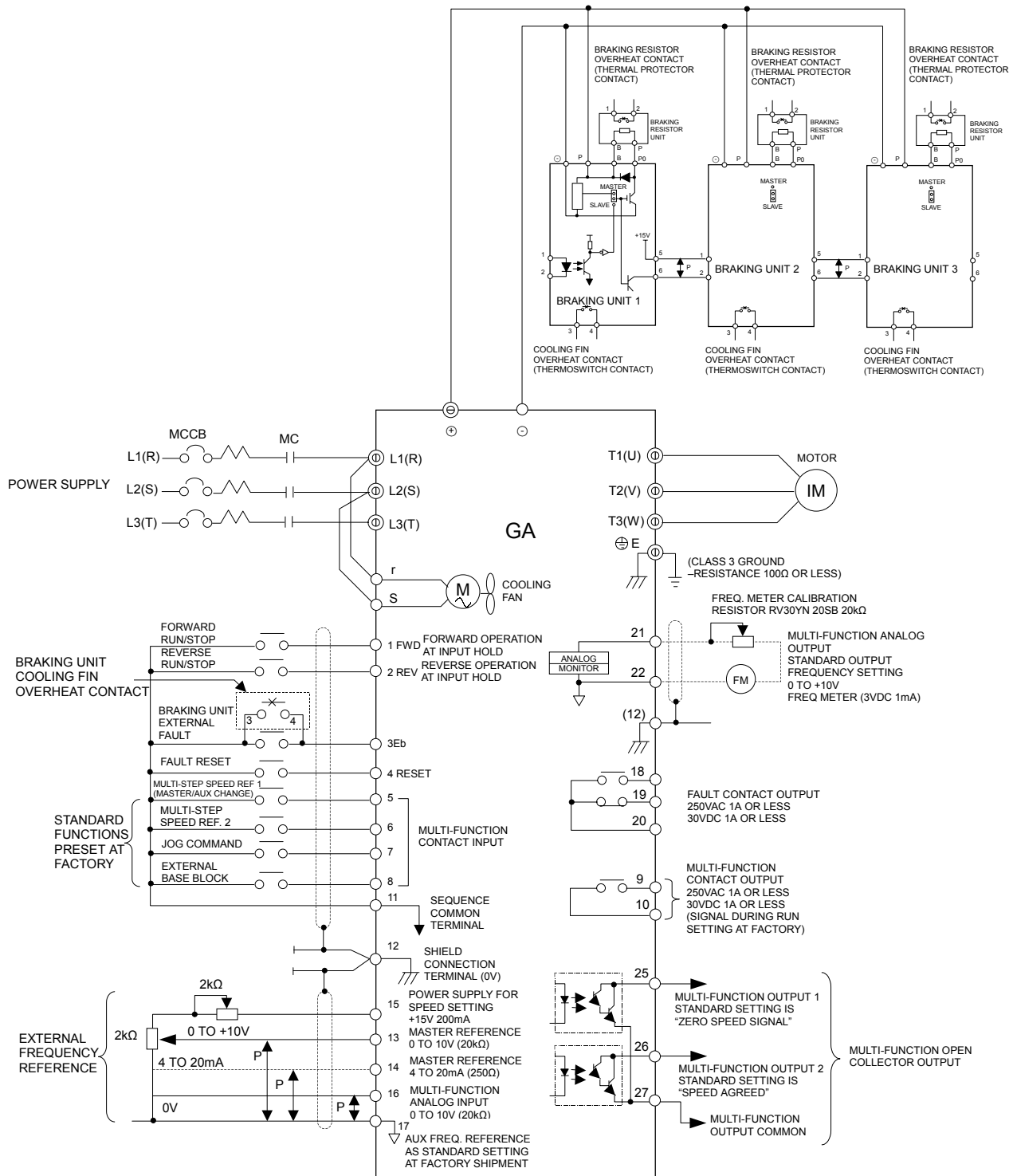

Notes: 1. indicates shielded wire and twisted-pair shielded wire.

2. External terminal 15 of +15V has maximum output current capacity of 20mA.

3. Either external terminal 13 or 14 can be used.

4. Terminal symbols: ⊙ indicates main circuit; ○ indicates control circuit.

(2) With Transistor Open Collector for Operation Signal

System Constant Setting

System Constant No.	Data			
	4th digit	3rd digit	2nd digit	1st digit
5r-04	-	-	0	0

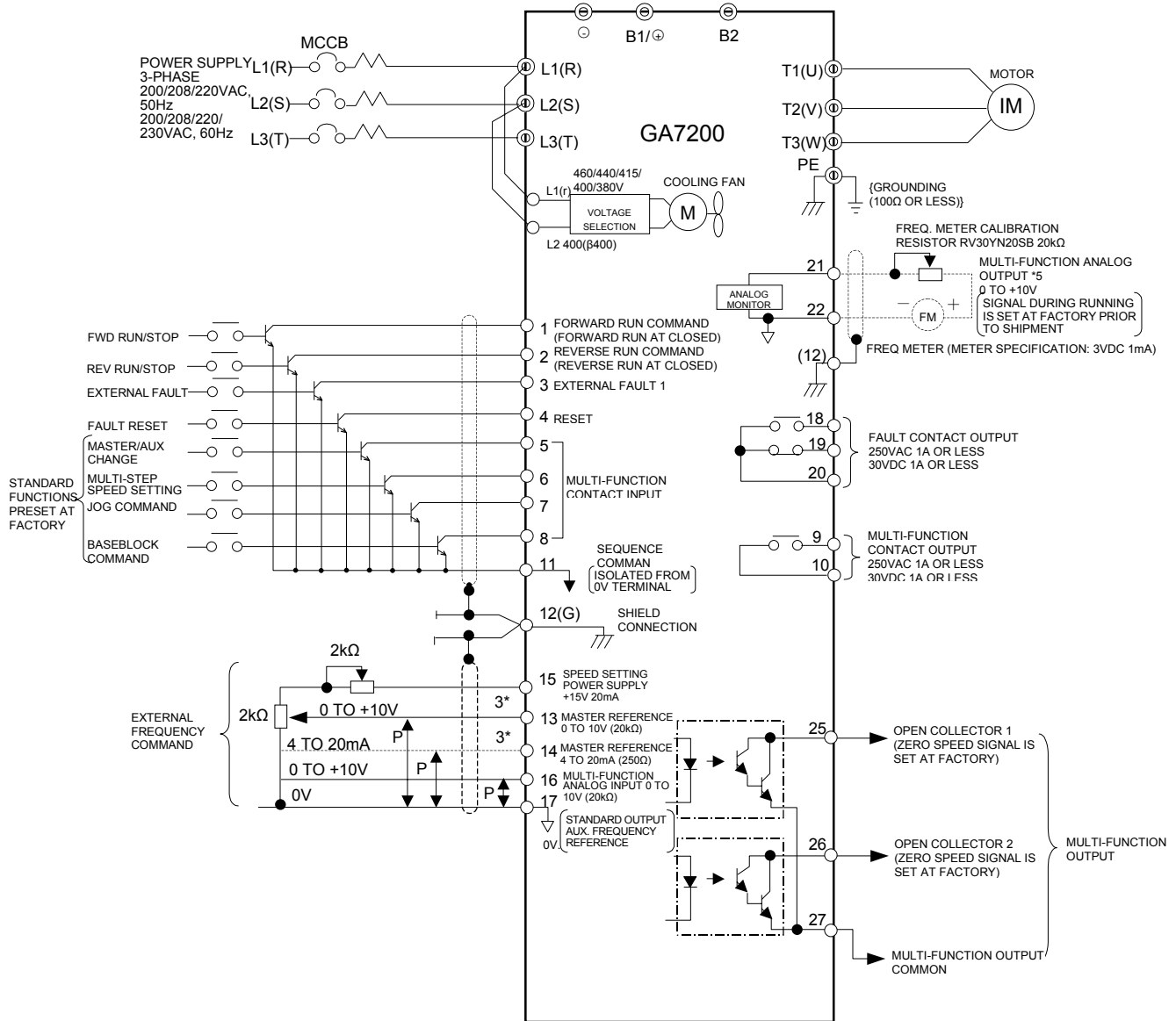

(3) With Contact Output, Photo-coupler Output

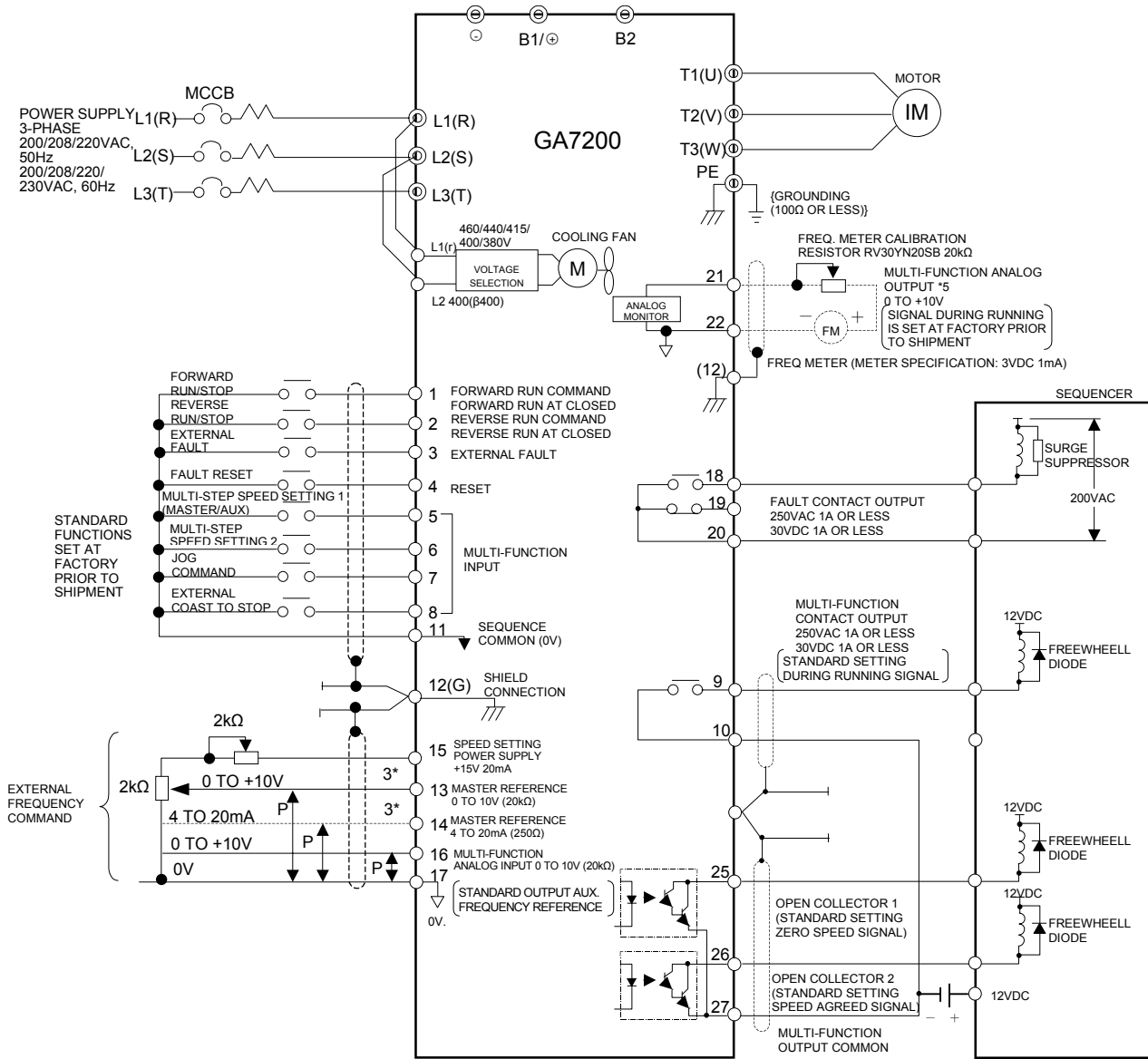

APPENDIX E

OPTION

(1) OPTION CARDS

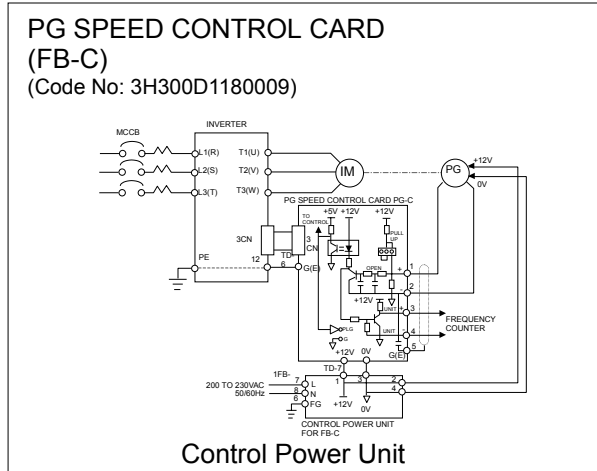

Permits compensation of speed variation caused by slip, by speed feedback using a pulse generator (PG) provided to the motor.

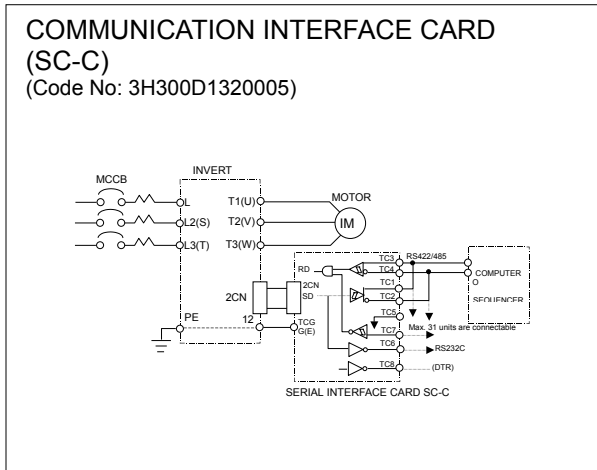

Permits operation or constant setting by command from master controller.

- Communication method: Synchronous
- Communication speed : 19.2kBPS (up to 136.5kBPS possible)
- Interface : RS-232, RS-422, RS-485

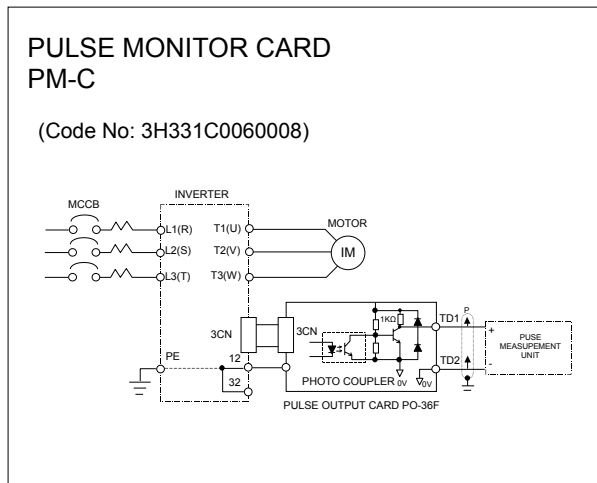

Outputs pulse train signal corresponding to the inverter output frequency.

- Output pulse : 1F, 6F, 10F, 12F, 36F (F: output freq.)
- Output voltage : +12V \pm 10% (isolated)
- Output current : 20mA max.

(2) PERIPHERALS (OPTIONAL UNITS)

Name	Model (Code No.)	Function	Installing Position	Reference
Exclusive Extension Cable for Digital Operator	1-meter cable (3H332D0010006) 3-meter cable (3H332D0020001)	This extension cable is used when the digital operator or digital monitor is used after being removed from the inverter front cover. The cable is available in 1- and 3-meter lengths. The package of the extension cable includes a simple blind panel.	On the inverter front cover (Blind panel)	—
BRAKING Resistor (Built-in Type)	(3H333C001)	Motor regenerative energy dissipation by the resistor reduces the decel time. (duty cycle 3% ED)	Mounted on the inverter bottom	
BRAKING Unit	(3H333C003)	Used in combination with the damping resistor unit to reduce motor deceleration time.	Separately installed	
BRAKING Resistor (Separate Installation Type)	(3H333C002)	Shortens the motor deceleration time by causing the regenerative energy to be consumed through the resistor.	Separately installed	

APPENDIX F

NOTES ON APPLICATION OF MOTORS

Motor Application Notes for Standard Motors

A standard motor driven by the inverter generates slightly less power than it does when it is driven with commercial power supply. Also, the cooling effect deteriorates in low speed range so that the motor temperature rise increases. Reduce load torque in the low speed range. Allowable load characteristics of the standard motor are shown in the figure. If 100% continuous torque is required in the low speed range, use an inverter duty motor.

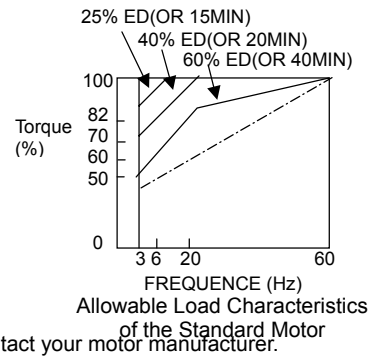

■ High speed operation

When the motor is used above 60Hz, motor mechanical design should be verified. Contact your motor manufacturer.

■ Torque characteristics

Motor torque characteristics vary when the motor is driven by an inverter instead of commercial power supply. Check the load torque characteristics of the machine to be connected.

■ Vibrations

Because of the high carrier modulation technique for PWM control, the GA7200 series reduces motor vibration to a level equal to running with a commercial power supply. Larger vibrations may occur under the following conditions:

(1) Response at resonant frequency of the mechanical system.

Special care is required if a machine which has previously been driven at a constant speed, is to be driven at varying speeds. Installation of anti-vibration rubber padding under the motor base and frequency jump control are recommended.

(2) Rotator residual imbalance

Special care is required for operation at 60Hz or higher frequencies.

■ Noise

Inverter operation is as quiet as operation with commercial power supply. At above rated speed (60Hz), noise may increase by motor cooling fan.

Application to Special Purpose Motors

Motors with Brakes	Use brake-equipped motors with an independent power supply. Connect the brake power supply to the inverter primary side. When the brake Operates (the motor stops) it turns the inverter output OFF. Some types of brakes may make abnormal sounds in low speed range.
Pole Change Motors	Select the inverter with a capacity exceeding the rated current of each pole. Pole change should be made only after the motor stops. If a pole is changed while the motor is rotating, the regenerative overvoltage or overcurrent protection circuit is activated and the motor coasts to a stop.
Submersible Motors	Since the rated current of underwater motors is large compared with general purpose motors, select an inverter with a larger capacity. If the wire length between the inverter and the motor is large, use cables with sufficiently large diameter.
Explosion-proof Motors	Explosion-proof motors which are applied to inverters must be currently approved as explosion-proof equipment. The inverter is not explosion-proof and should not be located where explosive gases exist.
Geared Motors	Lubrication method and continuous rotation limit differ with manufacturers. When oil lubrication is employed, continuous operation only in low speed range may cause burnout. Before operating the motor at more than 60Hz, you should consult the motor manufacturer.
Single-phase Motors	Single-phase motors are not suitable for variable speed operation with an inverter. If the inverter is applied to a motor using a capacitor stack, a high harmonic current flows and the capacitor may be damaged. For split-phase start motors and repulsion start motors, the internal centrifugal switch will not be actuated and the starting coil may be burned out. Therefore, only use 3-phase motors.

■ Power Transmission Mechanism (Gear Reduction, Belt, Chain, etc.)

When gear boxes and change/reduction gears lubricated with oil are used in power transmission systems, (Continuous low speed operation decreases the oil lubrication function). Also, operation at more than 60Hz may result in noise, reduced life, etc.

APPENDIX G

PERIPHERAL UNIT NOTES

■ Installation and selection of molded-case circuit breaker

On the input power side, a molded case circuit breaker (MCCB) to protect inverter primary wiring should be installed. The inverter power factor (depending on power voltage, output frequency, and load) must be taken into account for selecting the MCCB. For standard selection, see page 13. If a full electromagnetic MCCB is to be used, select a larger capacity because the operating characteristics are altered by harmonic current. A leakage current breaker of inverter use is recommended.

■ Use of input side magnetic contactor

The inverter can be used without an input side magnetic contactor (MC). An input MC can be used to prevent an automatic restart after recovery from an external power loss during remote control operation. However, do not use the MC frequently for start/stop operation, or it will lead to a reduced reliability. When the digital operator is used, automatic restart after power failure is disabled so that MC starting is impossible. Although the MC can stop the inverter, regeneration braking is disabled and the motor coasts to stop.

■ Use of secondary magnetic contactor

In general, magnetic contactors on the output of the inverter for motor control should not be used. Starting a motor with the inverter running will cause large surge currents and the inverter overcurrent protector to be triggered. If an MC is used for switching to commercial power supply, switch MC after the inverter and the motor stop. To switch during motor rotation, use the speed search function.

■ Use of overload relay

The inverter includes an electronic thermal protective function to protect the motor from overheating. If more than one motor is driven with a single inverter or when a multi-pole motor is used, place an overload relay between the inverter and the motor. Set 1 to the first position of Sn-14 (xxx1), and set the overload relay to the current nameplate value at 50Hz, or 1.1 times of that at 60 Hz.

■ Power-factor improvement (elimination of phase advance capacitor)

To improve the power-factor, install an AC reactor on the inverter's primary side. Power-factor improvement capacitors or surge suppressors on the inverter output side will be damaged by the harmonic component in the inverter output. Also, the overcurrent caused in the inverter output will trigger the overcurrent protection. To avoid this, do not use capacitors or surge suppressors in the inverter's output. To improve the power-factor, install an AC reactor on the inverter primary side.

■ Radio frequency interference

Because the inverter I/O (main circuit) contains a higher harmonics component, it may emit RFI noise to communication equipment (AM radio, etc.) near the inverter. Use a noise filter to decrease the noise. Use of a metallic conduit between the inverter and motor and grounding the conduit is also effective. Proper routing of input and output leads is also recommended.

■ Wire thickness and cable length

If the inverter is connected to a distant motor, (especially when low frequency is output,) motor torque decreases because of voltage drop in the cable. Use sufficiently heavy wire. When a digital operator is to be installed separately from the inverter, use the TECO connection cable (option). For remote control with analog signals, connect the operating pot or operating signal terminal and the inverter within 30m of the inverter. The cable must be routed separately from power circuits (main circuit and relay sequence circuit) so that it is not subjected to inductive interference by other equipment. If frequencies are set not only from the digital operator but also with external frequency controller, use twisted pair shielded wire as shown in the following figure and connect the shielding to terminal 12, not to the ground.

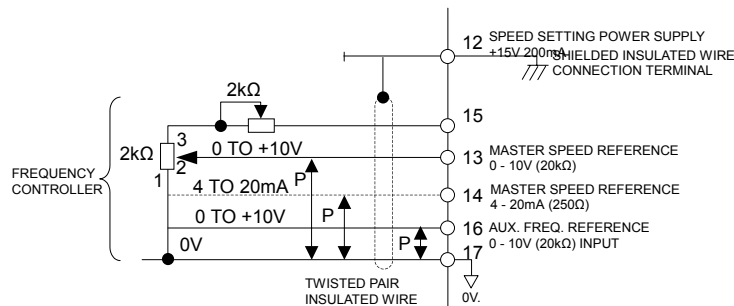

APPENDIX H

CIRCUIT PROTECTION AND ENVIRONMENTAL RATINGS NOTES

■ Circuit Protection

The maximum rms symmetrical amperes and voltage of GA7200 series are to listed as follows

Device Rating		Short circuit Rating (A)	Maximum Voltage (V)
Voltage	HP		
220V	1.5 ~ 50	5,000	240V
	51 ~ 100	10,000	
440V	1.5 ~ 50	5,000	480V
	51 ~ 200	10,000	
	201 ~ 500	18,000	

■ Environmental Ratings

The GA7200 is suitable for use in pollution degree 2 environments.

■ Field Wiring Terminals and Tightening Torque

The wiring terminals and tightening torque as follows.

(The main circuit terminal specifications – use 60/75°C copper wire only)

(a) 230V class

Circuit	Inverter Rating (HP)	Terminals Mark	Cable Size (AWG)	Terminals	Tightening Torque (pound-in.)
Main Circuit	1	L1, L2, L3, T1, T2, T3, B1/⊕, B2, ⊖	14 - 10	M4	10
		⊕	14 - 10	M4	10
	2	L1, L2, L3, T1, T2, T3, B1/⊕, B2, ⊖	14 - 10	M4	10
		⊕	12 - 10	M4	10
	3	L1, L2, L3, T1, T2, T3, B1/⊕, B2, ⊖	12 - 10	M4	10
		⊕	12 - 10	M4	10
	5	L1, L2, L3, T1, T2, T3, B1/⊕, B2, ⊖	10	M4	10
		⊕	10	M4	10
	7.5	L1, L2, L3, T1, T2, T3, B1/⊕, B2, ⊖	8	M5	21
		⊕	10 - 8	M5	21
	10	L1, L2, L3, T1, T2, T3, B1/⊕, B2, ⊖	8	M5	21
		⊕	10 - 8	M5	21
	15	L1, L2, L3, T1, T2, T3, B1/⊕, B2, ⊕2, ⊖	4	M6	35
		⊕	8	M6	35
	20	L1, L2, L3, T1, T2, T3, B1/⊕, B2, ⊕2, ⊖	2	M6	35
		⊕	8	M6	35
	25	L1, L2, L3, T1, T2, T3, ⊕1, ⊕2, ⊕3, ⊖	2	M8	78
		⊕	6	M8	78
	30	L1, L2, L3, T1, T2, T3, ⊕1, ⊕2, ⊕3, ⊖	1	M8	78
		⊕	6	M8	78
40	L1, L2, L3, T1, T2, T3, ⊕1, ⊕2, ⊕3, ⊖	4/0	M10	156	
	⊕	4	M8	78	
50	L1, L2, L3, T1, T2, T3, ⊕1, ⊕2, ⊕3, ⊖	2/0 x 2P	M10	156	
	⊕	4	M8	78	
60	L1, L2, L3, T1, T2, T3, ⊕1, ⊕2, ⊕3, ⊖	2/0 x 2P	M10	156	
	⊕	4	M8	78	
75	L1, L2, L3, T1, T2, T3, ⊕, ⊖	2/0 x 2P	M10	156	
	⊕	2	M8	78	
100	L1, L2, L3, T1, T2, T3, ⊕, ⊖	4/0 x 2P	M10	156	
	⊕	1/0	M10	156	
Control Circuit	All series	1 ~ 33	24 - 14	M3	5

(b) 460V class

Circuit	Inverter Rating (HP)	Terminals Mark	Cable Size (AWG)	Terminals	Tightening Torque (pound-inches)
Main Circuit	1	L1, L2, L3, T1, T2, T3, B1/⊕, B2, ⊖	14 - 10	M4	10
		⊕	14 - 10	M4	10
	2	L1, L2, L3, T1, T2, T3, B1/⊕, B2, ⊖	14 - 10	M4	10
		⊕	14 - 10	M4	10
	3	L1, L2, L3, T1, T2, T3, B1/⊕, B2, ⊖	14 - 10	M4	10
		⊕	14 - 10	M4	10
	5	L1, L2, L3, T1, T2, T3, B1/⊕, B2, ⊖	14 - 10	M4	10
		⊕	12 - 10	M4	10
	7.5	L1, L2, L3, T1, T2, T3, B1/⊕, B2, ⊖	12 - 10	M4	10
		⊕	12 - 10	M4	10
	10	L1, L2, L3, T1, T2, T3, B1/⊕, B2, ⊖	10	M4	10
		⊕	10	M4	10
	15	L1, L2, L3, T1, T2, T3, B1/⊕, B2, ⊕2, ⊖	8 - 6	M6	35
		⊕	8	M6	35
	20	L1, L2, L3, T1, T2, T3, B1/⊕, B2, ⊕2, ⊖	8 - 6	M6	35
		⊕	8	M6	35
	25	L1, L2, L3, T1, T2, T3, ⊕1, ⊕2, ⊕3, ⊖	6	M8	78
		⊕	8	M10	156
	30	L1, L2, L3, T1, T2, T3, ⊕1, ⊕2, ⊕3, ⊖	4	M8	78
		⊕	8	M10	156
	40	L1, L2, L3, T1, T2, T3, ⊕1, ⊕2, ⊕3, ⊖	4	M8	78
		⊕	8	M10	156
	50	L1, L2, L3, T1, T2, T3, ⊕1, ⊕2, ⊕3, ⊖	2	M8	78
		⊕	6	M10	156
	60	L1, L2, L3, T1, T2, T3, ⊕1, ⊕2, ⊕3, ⊖	1/0	M8	78
		⊕	6	M10	156
	75	L1, L2, L3, T1, T2, T3, ⊕, ⊖	4/0	M10	156
		⊕	4	M10	156
	100	L1, L2, L3, T1, T2, T3, ⊕, ⊖	2/0 x 2P	M10	156
		⊕	4	M10	156
	125	L1, L2, L3, T1, T2, T3, ⊕, ⊖	2/0 x 2P	M10	156
		⊕	4	M10	156
	150	L1, L2, L3, T1, T2, T3, ⊕, ⊖	2/0 x 2P	M10	156
⊕		2	M10	156	
175	L1, L2, L3, T1, T2, T3, ⊕, ⊖	2/0 x 2P	M10	156	
	⊕	2	M10	156	
215	L1, L2, L3, T1, T2, T3, ⊕, ⊖	4/0 x 2P	M10	156	
	⊕	1/0	M10	156	
250	L1, L2, L3, T1, T2, T3, ⊕, ⊖	650 x 2P	M12	277	
	⊕	1/0	M10	156	
300,350	L1, L2, L3, T1, T2, T3, ⊕, ⊖	650 x 2P	M12	277	
	⊕	1/0	M10	156	
400,450	L1, L2, L3, T1, T2, T3, ⊕, ⊖	650 x 2P	M12	277	
	⊕	2/0	M10	156	
Control Circuit	All series	1 ~ 33	20 - 14	M3	5

I. DETAIL DIMENSIONS OF 250HP TO 450HP

VOLT-AGE	INVERTER HP	APPROXIMATE DIMENSIONS (mm)														ACL	Ref. Figure
		OPEN CHASSIS TYPE (IP00)						Weight (kg)	ENCLOSED TYPE (NEMA1)(IP20)						Weight (kg)		
		W	H	D	W1	H1	d		W	H	D	W1	H1	d			
460V	250	730	1230	382	690	930	M12	160	730	1330	382	690	930	M12	166	External	(a)
	170							176							(b)		
	190							196							(b)		

(a) 460V : 250HP

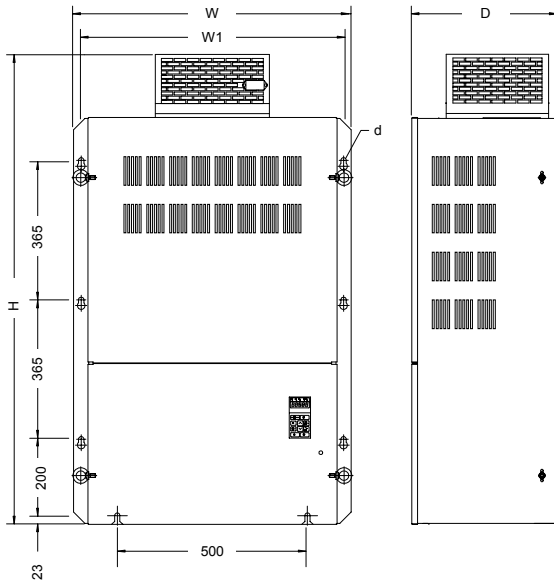

(Open chassis type – IP00)

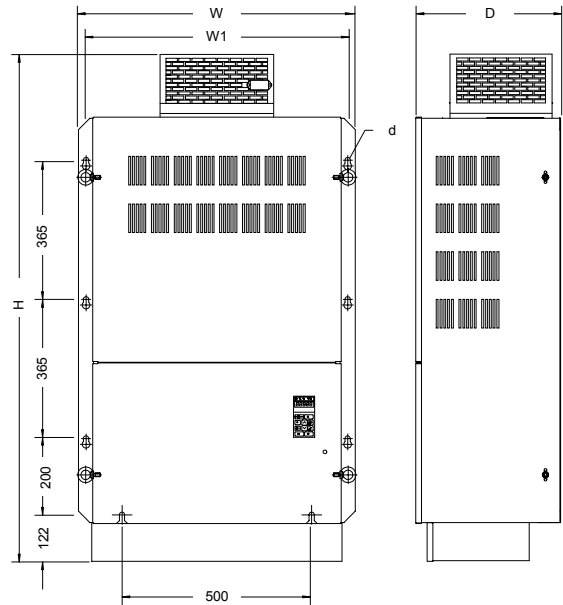

(Wall-mounted type – NEMA1)

(b) 460V : 300HP~450HP

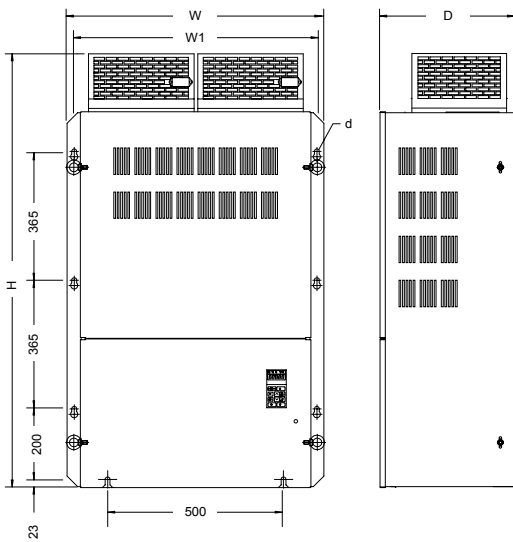

(Open chassis type – IP00)

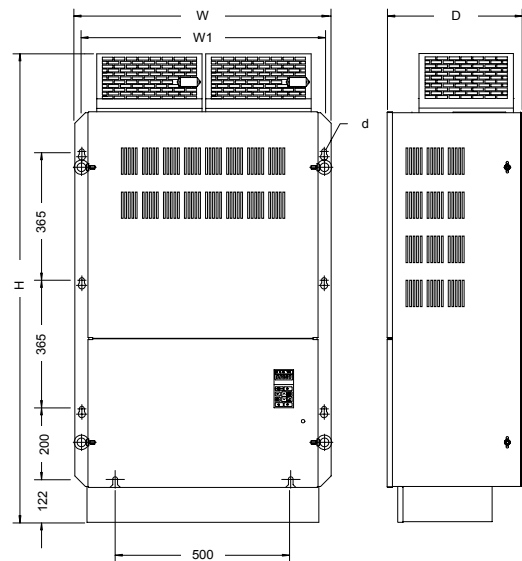

(Wall-mounted type – NEMA1)

DISTRIBUTED BY:



M O T O R C O M P A N Y

5100 NORTH IH-35 ROUND ROCK, TEXAS 78681

[www. tecowestinghouse. com](http://www.tecowestinghouse.com)

12/1/2002